

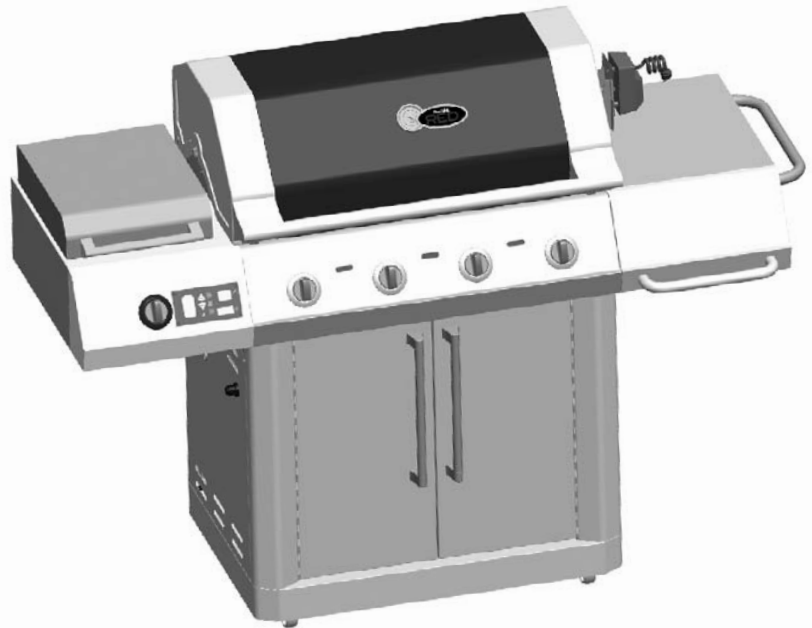

MODEL 463250308 • PRODUCT GUIDE



CONVERSION-READY CONVERSIÓN-INMEDIATA

Easily converts from (LP) liquid propane to (NG) natural gas
Conversión fácil de propano líquido (LP) al gas natural (GN)

Visit the grill accessory aisle for a complete kit.
Visite el pasillo de accesorios para parrillas para adquirir un kit completo.

THIS GRILL IS FOR OUTDOOR USE ONLY.

CAUTION:

Read and follow all safety statements, assembly instructions, and use and care directions before attempting to assemble and cook.

INSTALLER/ASSEMBLER:

Leave this manual with consumer.

CONSUMER:

Keep this manual for future reference.

WARNING:

Failure to follow all manufacturer's instructions could result in serious personal injury and/or property damage.

CAUTION:

Some parts may contain sharp edges – especially as noted in the manual! Wear protective gloves if necessary.

If you have questions or need assistance during assembly, please call 1-888-430-7870.

To insure your satisfaction and for follow-up service, register your grill online at www.grillregistration.com

 **DANGER** 

If you smell gas:

1. Shut off gas to the appliance.
2. Extinguish any open flame.
3. Open lid.
4. If odor continues, keep away from the appliance and immediately call your gas supplier or your fire department.

 **WARNING** 

CALIFORNIA PROPOSITION 65

1. Combustion by-products produced when using this product contain chemicals known to the State of California to cause cancer, birth defects, and other reproductive harm.
2. This product contains chemicals, including lead and lead compounds, known to the State of California to cause cancer, birth defects or other reproductive harm.

Wash your hands after handling this product.

 **WARNING** 

1. Do not store or use gasoline or other flammable liquids or vapors in the vicinity of this or any other appliance.
2. An LP cylinder not connected for use shall not be stored in the vicinity of this or any other appliance.

Installation Safety Precautions

- Use grill, as purchased, only with LP (propane) gas and the regulator/valve assembly supplied. A conversion kit must be purchased for use with natural gas.
- Grill installation must conform with local codes, or in their absence of local codes, with either the *National Fuel Gas Code, ANSI Z223.1/ NFPA 54, Natural Gas and Propane Installation Code, CSA B149.1, or Propane Storage and Handling Code, B149.2, or the Standard for Recreational Vehicles, ANSI A 119.2/NFPA 1192, and CSA Z240 RV Series, Recreational Vehicle Code, as applicable.*
- All electrical accessories (such as rotisserie) must be electrically grounded in accordance with local codes, or *National Electrical Code, ANSI / NFPA 70 or Canadian Electrical Code, CSA C22.1.* Keep any electrical cords and/or fuel supply hoses away from any hot surfaces.
- This grill is safety certified for use in the United States and/or Canada only. Do not modify for use in any other location. Modification will result in a safety hazard.

Call Grill Service Center for Help and Parts

- If you need assistance with your product or warranty parts call **1-888-430-7870. Hours of Service Center Operation are 8:00 A.M. To 6:00 P.M. EST Monday - Friday.**
- To order non-warranty replacement parts or accessories please visit us on the web at www.charbroil.com or call 1-888-430-7870 and one of our friendly and knowledgeable agents will be glad to assist you.

Safety Symbols

The symbols and boxes shown below explain what each heading means. Read and follow all of the messages found throughout the manual.

IMPORTANT: Fill out the product record information below.

Model Number _____

Serial Number _____
See rating label on grill for serial number.

Date Purchased _____

 **DANGER** 

DANGER: Indicates an imminently hazardous situation which, if not avoided, will result in death or serious injury.

 **WARNING** 

WARNING: Indicates an potentially hazardous situation which, if not avoided, could result in death or serious injury.

 **CAUTION** 

CAUTION: Indicates a potentially hazardous situation or unsafe practice which, if not avoided, may result in minor or moderate injury.

 **CAUTION** 

For residential use only. Do not use for commercial cooking.

TABLE OF CONTENTS

For Your Safety.....	2
Grill Service Center.....	2
Product Record Information.....	2
Installation Safety Precautions.....	2
Safety Symbols.....	2
Use and Care	4-12
Parts List.....	13
Parts Diagram.....	14
Assembly.....	15-24
Troubleshooting.....	25-27
Warranty.....	28
Registration Card.....	29

**To insure your satisfaction
and for follow-up service,
register your grill
online at:
www.grillregistration.com**

USE AND CARE



DANGER



- **NEVER** store a spare LP cylinder under or near the appliance or in an enclosed area.

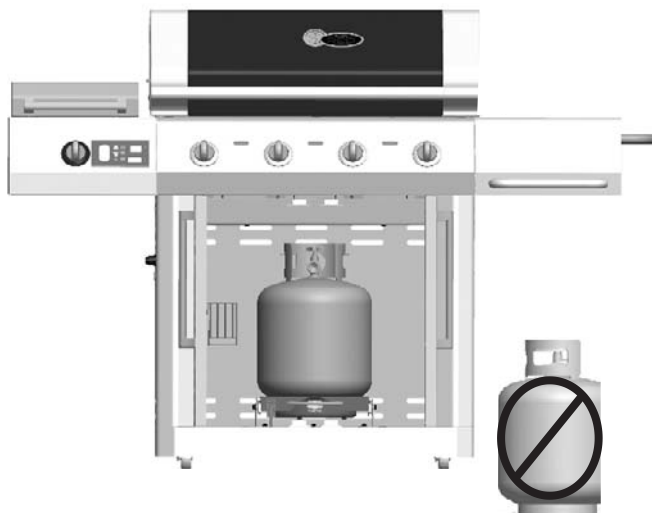

- **Never** fill a cylinder beyond 80% full.
- An over filled or improperly stored cylinder is a hazard due to possible gas release from the safety relief valve.
- If you see, smell or hear gas escaping, immediately get away from the LP cylinder/appliance and call your fire department.
- This could cause an intense fire with risk of property damage, serious injury or death.

LP Cylinder Removal, Transport and Storage

- Turn OFF all control knobs and LP cylinder valve. Turn coupling nut counterclockwise by hand only - do not use tools to disconnect. Loosen cylinder screw beneath bottom shelf, then lift LP cylinder up and out of cart. Install safety cap onto LP cylinder valve. Always use cap and strap supplied with valve. **Failure to use safety cap as directed may result in serious personal injury and/or property damage.**

- A disconnected LP cylinder in storage or being transported must have a safety cap installed (as shown). Do not store an LP cylinder in enclosed spaces such as a carport, garage, porch, covered patio or other building. Never leave an LP cylinder inside a vehicle which may become overheated by the sun.

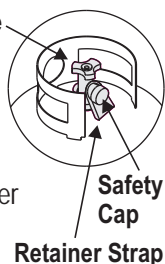

- Do not store an LP cylinder in an area where children play.

LP Cylinder

- **The LP cylinder used with your grill must meet the following requirements:**

- Use LP cylinders only with these required measurements: 12" (30.5cm) (diameter) x 18" (45.7 cm) (tall) with 20 lb. (9 kg.) capacity maximum.
- LP cylinders must be constructed and marked in accordance with specifications for LP cylinders of the U.S. Department of Transportation (DOT) or for Canada, CAN/CSA-B339, cylinders, spheres and tubes for transportation of dangerous goods. Transport Canada (TC). See LP cylinder collar for marking.

- LP cylinder valve must have:
 - Type 1 outlet compatible with regulator or grill.
 - Safety relief valve.
 - UL listed Overfill Protection Device (OPD). This OPD safety feature is identified by a unique triangular hand wheel. **Use only LP cylinders equipped with this type of valve.**



OPD Hand Wheel

- LP cylinder must be arranged for vapor withdrawal and include collar to protect LP cylinder valve. Always keep LP cylinders in upright position during use, transit or storage.



LP cylinder in upright position for vapor withdrawal

LP (Liquefied Petroleum Gas)

- LP gas is nontoxic, odorless and colorless when produced. **For Your Safety**, LP gas has been given an odor (similar to rotten cabbage) so that it can be smelled.
- LP gas is highly flammable and may ignite unexpectedly when mixed with air.

LP Cylinder Filling

- Use only licensed and experienced dealers.
- LP dealer **must purge new cylinder** before filling.
- Dealer should **NEVER** fill LP cylinder more than 80% of LP cylinder volume. Volume of propane in cylinder will vary by temperature.
- A frosty regulator indicates gas overfill. Immediately close LP cylinder valve and call local LP gas dealer for assistance.
- Do not release liquid propane (LP) gas into the atmosphere. This is a hazardous practice.
- To remove gas from LP cylinder, contact an LP dealer or call a local fire department for assistance. Check the telephone directory under "Gas Companies" for nearest certified LP dealers.

LP Cylinder Exchange

- Many retailers that sell grills offer you the option of replacing your empty LP cylinder through an exchange service. Use only those reputable exchange companies that inspect, precision fill, test and certify their cylinders. **Exchange your cylinder only for an OPD safety feature-equipped cylinder as described in the "LP Cylinder" section of this manual.**
- Always keep new and exchanged LP cylinders in upright position during use, transit or storage.
- **Leak test new and exchanged LP cylinders BEFORE connecting to grill.**

LP Cylinder Leak Test

For your safety

- Leak test must be repeated each time LP cylinder is exchanged or refilled.
- Do not smoke during leak test.
- Do not use an open flame to check for gas leaks.
- Grill must be leak tested outdoors in a well-ventilated area, away from ignition sources such as gas fired or electrical appliances. During leak test, keep grill away from open flames or sparks.
- Use a clean paintbrush and a 50/50 mild soap and water solution. Brush soapy solution onto areas indicated by arrows in figure below.
- † **Do not use household cleaning agents.** Damage to gas train components can result.

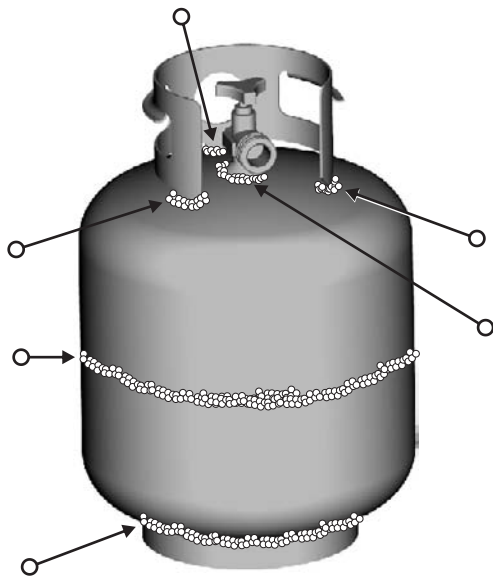

	WARNING	
If "growing" bubbles appear do not use or move the LP cylinder. Contact an LP gas supplier or your fire department!		

Connecting Regulator to the LP Cylinder

1. LP cylinder must be properly secured onto grill. (Refer to assembly section.)
2. Turn all control knobs to the OFF position.
3. Turn LP cylinder OFF by turning hand-wheel clockwise to a **full stop**.
4. Remove the protective cap from LP cylinder valve. Always use cap and strap supplied with valve.

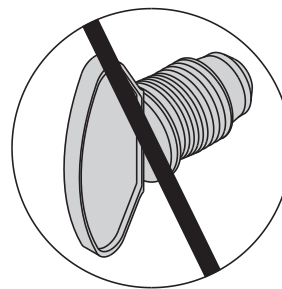
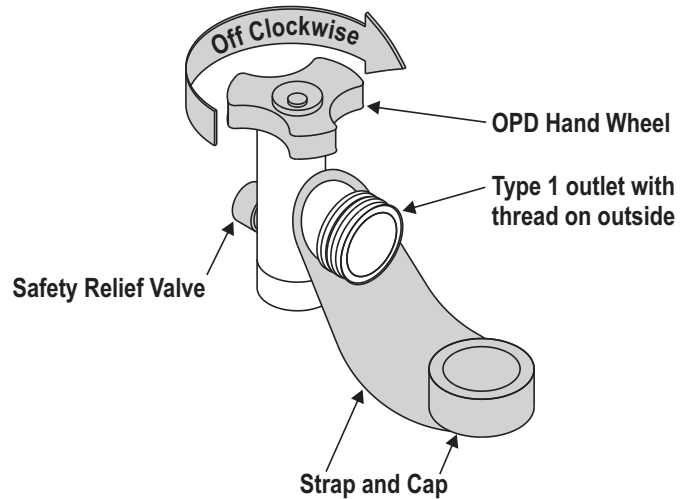

Do not use a POL transport plug (plastic part with external threads)! It will defeat the safety feature of the valve.

5. Hold regulator and insert nipple into LP cylinder valve. Hand-tighten the coupling nut, holding regulator in a straight line with LP cylinder valve so as not to cross-thread the connection.

Nipple has to be centered into the LP cylinder valve.

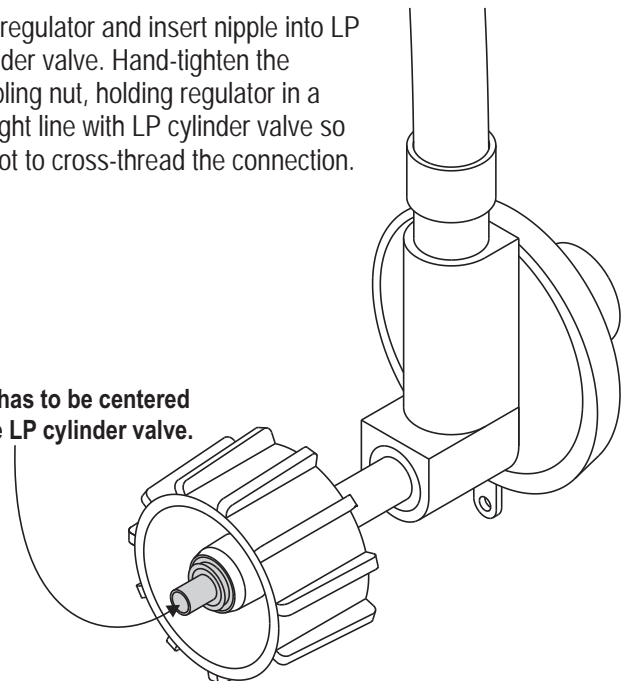

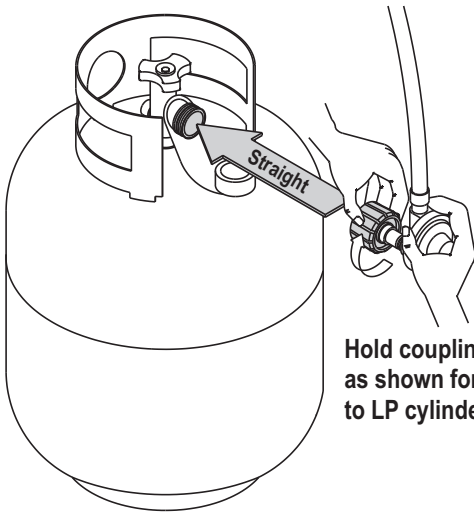

Hold coupling nut and regulator as shown for proper connection to LP cylinder valve.

6. Turn the coupling nut clockwise and tighten to a full stop. The regulator will seal on the back-check feature in the LP cylinder valve, resulting in some resistance. **An additional one-half to three-quarters turn is required to complete the connection. Tighten by hand only – do not use tools.**

NOTE:

If you cannot complete the connection, disconnect regulator and repeat steps 5 and 6. If you are still unable to complete the connection, **do not use this regulator!**

	DANGER	
<ul style="list-style-type: none"> Do not insert any tool or foreign object into the valve outlet or safety relief valve. You may damage the valve and cause a leak. Leaking propane may result in explosion, fire, severe personal injury, or death. 		

	WARNING	
<ul style="list-style-type: none"> Outdoor gas appliance is not intended to be installed in or on a boat. Outdoor gas appliance is not intended to be installed in or on an RV. Never attempt to attach this grill to the self-contained LP gas system of a camper trailer or motor home. Do not use grill until leak-tested. If a leak is detected at any time, STOP and call the fire department. If you cannot stop a gas leak, <i>immediately</i> close LP cylinder valve and call LP gas supplier or your fire department! 		

Leak Testing Valves, Hose and Regulator

1. Turn all grill control knobs to OFF.
2. Be sure regulator is tightly connected to LP cylinder.
3. Completely open LP cylinder valve by turning hand wheel counterclockwise. If you hear a *rushing sound*, turn gas off immediately. There is a major leak at the connection. **Correct before proceeding.**
4. Brush soapy solution onto areas circled below.

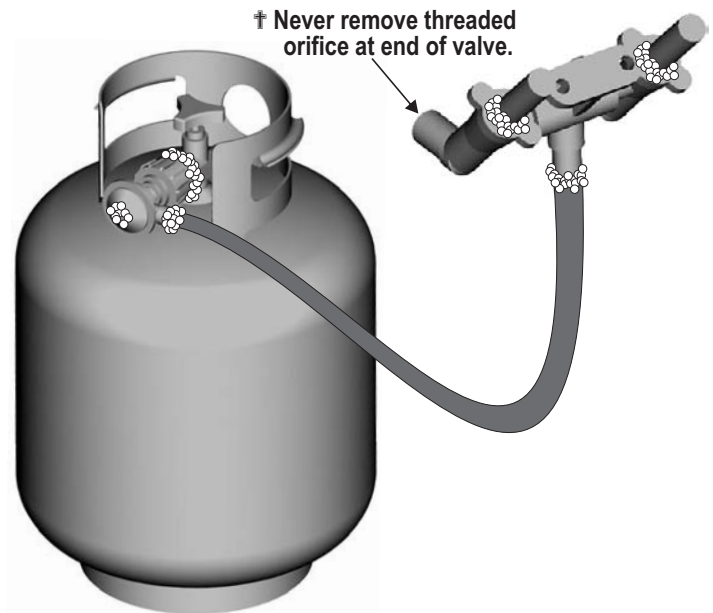

5. If “growing” bubbles appear, there is a leak. Close LP cylinder valve immediately and retighten connections. **If leaks cannot be stopped do not try to repair.** Call for replacement parts. Order new parts by giving the serial, model number and name and part number of items needed (see parts list) to the Grill Service Center at 1-888-430-7870.
6. Always close LP cylinder valve after performing leak test by turning hand wheel clockwise.



WARNING



For Safe Use of Your Grill and to Avoid Serious Injury:

- Do not let children operate or play near grill.
- Keep grill area clear and free from materials that burn.
- Do not block holes in sides or back of grill.
- Check burner flames regularly.
- Use grill only in well-ventilated space. NEVER use in enclosed space such as carport, garage, porch, covered patio, or under an overhead structure of any kind.
- Do not use charcoal or ceramic briquets in a gas grill. (*Unless briquets are supplied with your grill.*)
- **Use grill at least 3 ft. from any wall or surface.** Maintain 10 ft. clearance to objects that can catch fire or sources of ignition such as pilot lights on water heaters, live electrical appliances, etc.

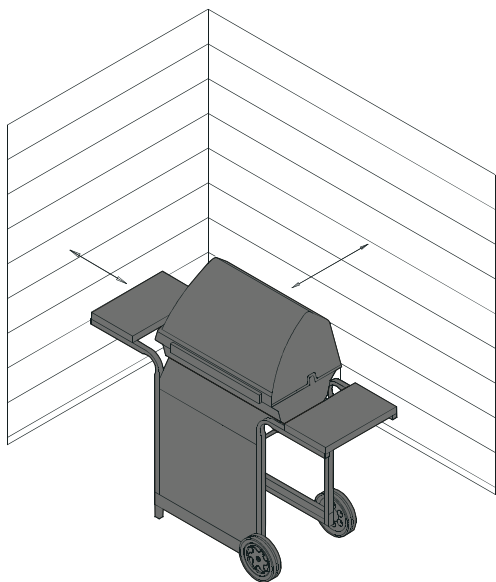

• Apartment Dwellers:

Check with management to learn the requirements and fire codes for using an LP gas grill in your apartment complex. If allowed, use outside on the ground floor with a three (3) foot clearance from walls or rails. Do not use on or under balconies.

- **NEVER attempt to light burner with lid closed. A buildup of non-ignited gas inside a closed grill is hazardous.**
- **Never operate grill with LP cylinder out of correct position specified in assembly instructions.**
- **Always close LP cylinder valve and remove coupling nut before moving LP cylinder from specified operation position.**

Safety Tips

- † Before opening LP cylinder valve, check the coupling nut for tightness.
- † When grill is not in use, turn off all control knobs and LP cylinder valve.
- † Never move grill while in operation or still hot.
- † Use long-handled barbecue utensils and oven mitts to avoid burns and splatters.
- † Maximum load for sideburner and side shelf is 10 lbs.
- † The grease tray **must** be inserted into grill and emptied after each use. Do not remove grease tray until grill has completely cooled.
- † Clean grill often, preferably after each cookout. If a bristle brush is used to clean any of the grill cooking surfaces, ensure no loose bristles remain on cooking surfaces prior to grilling. It is not recommended to clean cooking surfaces while grill is hot.
- † If you notice grease or other hot material dripping from grill onto valve, hose or regulator, turn off gas supply at once. Determine the cause, correct it, then clean and inspect valve, hose and regulator before continuing. Perform a leak test.
- † Keep ventilation openings in cylinder enclosure (grill cart) free and clear of debris.
- † Do not store objects or materials inside the grill cart enclosure that would block the flow of combustion air to the underside of either the control panel or the firebox bowl.
- † The regulator may make a humming or whistling noise during operation. This will not affect safety or use of grill.
- † If you have a grill problem see the "Troubleshooting Section".
- † If the regulator frosts, turn off grill and LP cylinder valve immediately. This indicates a problem with the cylinder and it should not be used on any product. Return to supplier!





CAUTION



- **Putting out grease fires by closing the lid is not possible. Grills are well ventilated for safety reasons.**
- **Do not use water on a grease fire. Personal injury may result. If a grease fire develops, turn knobs and LP cylinder off.**
- **Do not leave grill unattended while preheating or burning off food residue on clean. If grill has not been regularly cleaned, a grease fire can occur that may damage the product.**

Main Burner Ignitor Lighting

- † **Do not lean over grill while lighting.**
- 1. Turn OFF all Gas Burner Control Valves.
- 2. Turn ON gas source or tank.
- 3. Open lid during Lighting.
- 4. To ignite turn burner control valve to .
- 5. Once burner has ignited (use flame viewing ports on front of control panel to verify ignition), turn knob to desired setting.
- 6. If Ignition does not occur in 5 seconds, turn the burner controls  OFF, wait 5 minutes, and repeat the lighting procedure.
- 7. Ignite remaining burners by repeating steps 4 through 6 for each burner.

Lighting instructions continued on next page.



WARNING



Turn controls and gas source or tank OFF when not in use.





CAUTION



If ignition does NOT occur in 5 seconds, turn the burner controls OFF, wait 5 minutes and repeat the lighting procedure. If the burner does not ignite with the valve open, gas will continue to flow out of the burner and could accidentally ignite with risk of injury.

Main Burner Match-Lighting

† **Do not lean over grill while lighting.**

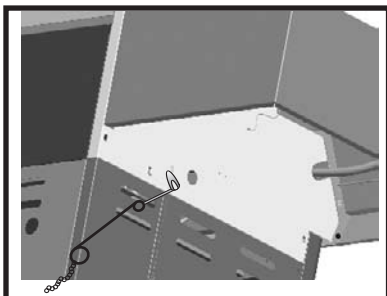

1. Open lid during lighting.
2. Place match into match holder (hanging from side of cart). Light match, place into lighting hole on right or left side of firebox.
3. Push in and turn far right or far left knob to  position. Be sure burner lights and stays lit.
4. If ignition does NOT occur in 5 seconds, turn the burner control knob OFF, wait 5 minutes, and repeat the lighting procedure
5. Light other burners by pushing knob in and turning to  position.



Warning:
Top cover must be open when side burner(s) is in operation.

side burner Ignitor Lighting

† **Do not lean over grill while lighting.**



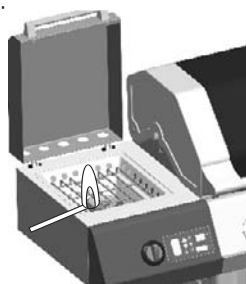

1. Turn OFF all gas burner control valves.
2. Turn ON gas source or tank.
3. To ignite side burner, open side burner cover.
4. Turn side burner knob to , to ignite burner.
5. Once burner has ignited, turn knob to desired setting.
6. If side burner does not light, turn knob to  OFF, wait 5 minutes, then repeat lighting procedure.

side burner Match Lighting

1. Open lid during lighting. Turn on gas at LP cylinder.
2. Place lit match near burner.
3. Turn side burner knob to .



Burner Flame Check

- Remove cooking grates and troughs. Light burners, rotate knobs from  to . You should see a bigger flame in  position than seen on . Perform burner flame check on side burner, also. Always check flame prior to each use. If only low flame is seen refer to "Sudden drop or low flame" in the *Troubleshooting Section*.

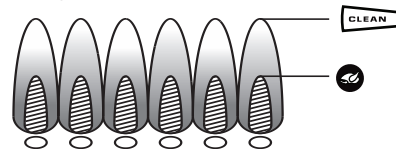

Turning Grill Off

- Turn all knobs to **OFF**  position. Turn LP cylinder off by turning hand-wheel clockwise to a full stop.

Ignitor Check

- **Turn gas off at LP cylinder.** Press and hold electronic ignitor button. "Click" should be heard and spark seen each time between collector box or burner and electrode. See "*Troubleshooting*" if no click or spark.

Valve Check

- **Important: Make sure gas is off at LP cylinder before checking valves.** Knobs lock in **OFF** position. To check valves, first push in knobs and release, knobs should spring back. If knobs do not spring back, replace valve assembly before using grill. Turn knobs to **LOW** position then turn back to **OFF** position. Valves should turn smoothly.

Hose Check

- Before each use, check to see if hoses are cut or worn. Replace damaged hoses before using grill. Use only valve/hose/regulator specified by manufacturer.

General Grill Cleaning

- Do not mistake brown or black accumulation of grease and smoke for paint. Interiors of gas grills are not painted at the factory (**and should never be painted**). Apply a strong solution of detergent and water or use a grill cleaner with scrub brush on insides of grill lid and bottom. Rinse and allow to completely air dry. **Do not apply a caustic grill/oven cleaner to painted surfaces.**
- **Plastic parts:** Wash with warm soapy water and wipe dry.
 - † Do not use citrisol, abrasive cleaners, degreasers or a concentrated grill cleaner on plastic parts. Damage to and failure of parts can result.
- **Porcelain surfaces:** Because of glass-like composition, most residue can be wiped away with baking soda/water solution or specially formulated cleaner. Use nonabrasive scouring powder for stubborn stains.
- **Painted surfaces:** Wash with mild detergent or nonabrasive cleaner and warm soapy water. Wipe dry with a soft nonabrasive cloth.
- **Stainless steel surfaces:** To maintain your grill's high quality appearance, wash with mild detergent and warm soapy water and wipe dry with a soft cloth after each use. Baked-on grease deposits may require the use of an abrasive plastic cleaning pad. Use only in direction of brushed finish to avoid damage. Do not use abrasive pad on areas with graphics.
- **Cooking surfaces:** If a bristle brush is used to clean any of the grill cooking surfaces, ensure no loose bristles remain on cooking surfaces prior to grilling. It is not recommended to clean cooking surfaces while grill is hot.



CAUTION



SPIDER ALERT!

SPIDER AND WEBS
INSIDE BURNER TUBE



If you notice that your grill is getting hard to light or that the flame isn't as strong as it should be, take the time to check and clean the venturi's.

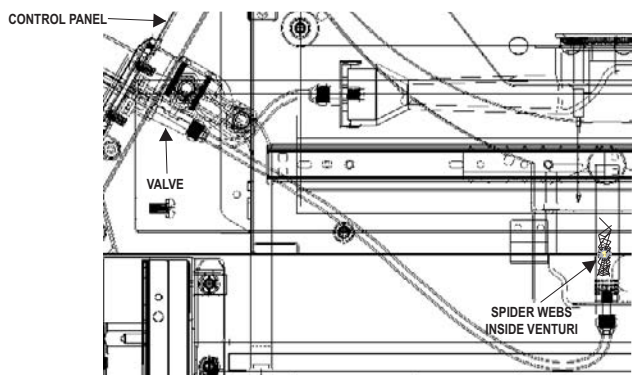

In some areas of the country, spiders or small insects have been known to create "flashback" problems. The spiders spin webs, build nests and lay eggs in the grill's venturi tube(s) obstructing the flow of gas to the burner. The backed-up gas can ignite in the venturi behind the control panel. This is known as a flashback and it can damage your grill and even cause injury.

To prevent flashbacks and ensure good performance the burner and venturi assembly should be removed from the grill and cleaned before use whenever the grill has been idle for an extended period.

Cleaning the Burner Assembly

Follow these instructions to clean and/or replace parts of burner assembly or if you have trouble igniting grill.

1. **Turn gas off at control knobs and LP cylinder.**
2. Remove cooking grates and flame tamers.
3. Remove screws and carryover tubes from rear of burners.
4. Remove screw and washers to disengage burner from bracket on firebox.
5. Remove screws to detach electrode from burner. Electrode should remain in firebox.
6. Carefully lift each burner up and away from valve openings.

We suggest three ways to clean the burner tubes. Use the one easiest for you.

- (A) Bend a stiff wire (a light weight coat hanger works well) into a small hook. Run the hook through each burner tube several times.



- (B) Use a narrow bottle brush with a flexible handle (do not use a brass wire brush), run the brush through each burner tube several times.

- (C) **Wear eye protection:** Use an air hose to force air into the burner tube and out the burner ports. Check each port to make sure air comes out each hole.

7. Wire brush entire outer surface of burner to remove food residue and dirt.
8. Clean any blocked ports with a stiff wire such as an open paper clip.
9. Check burner for damage, due to normal wear and corrosion some holes may become enlarged. If any large cracks or holes are found replace burner.

VERY IMPORTANT: Burner tubes must reengage valve openings. See illustrations at right.

Correct
burner-to-valve
engagement

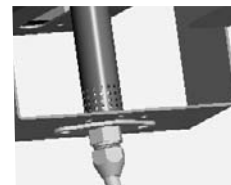

10. Attach electrode to burner.
11. Carefully replace burners.
12. Attach burners to brackets on firebox.
13. Reposition carryover tubes and attach to burners. Replace flame tamers and cooking grates.

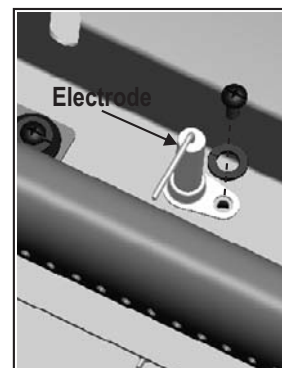
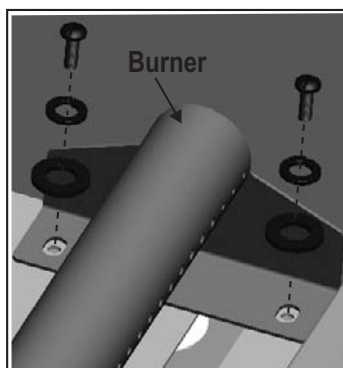

Storing Your Grill

- Clean cooking grates.
- Store in dry location.
- When LP cylinder is connected to grill, store outdoors in a well-ventilated space and out of reach of children.
- Cover grill if stored outdoors. Choose from a variety of grill covers offered by manufacturer.
- Store grill indoors ONLY if LP cylinder is turned off and disconnected, removed from grill and stored outdoors.
- When removing grill from storage, follow "Cleaning the Burner Assembly" instructions before starting grill.

Food Safety

Food safety is a very important part of enjoying the outdoor cooking experience. To keep food safe from harmful bacteria, follow these four basic steps:

Clean: Wash hands, utensils, and surfaces with hot soapy water before and after handling raw meat and poultry.

Separate: Separate raw meats and poultry from ready-to-eat foods to avoid cross contamination. Use a clean platter and utensils when removing cooked foods.

Cook: Cook meat and poultry thoroughly to kill bacteria. Use a thermometer to ensure proper internal food temperatures.

Chill: Refrigerate prepared foods and leftovers promptly.

For more information call: USDA Meat and Poultry Hotline at 1-800-535-4555 In Washington, DC (202) 720-3333, 10:00 am-4:00 pm EST.

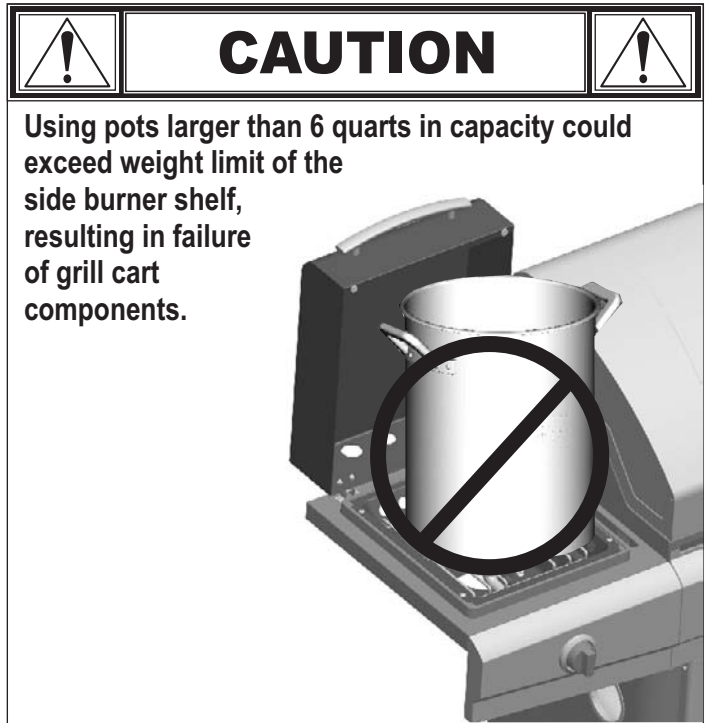

Digital Display Panel

Available only on certain models.

Temperature °C/°F: To toggle between Celcius & Fahrenheit, depress this button.

Power / BackLight: To power the unit On/Off. To turn the unit off, hold down the  button for 5 seconds. Also press the  button quickly to turn On/Off the LCD control panel backlight.

Gas Tank Gauge Indicator

The LP Gas Cylinder has been split up into 5 equal capacity measurements, each of which measures approximately 20% of the entire cylinder (approximately 4.2 pounds each).

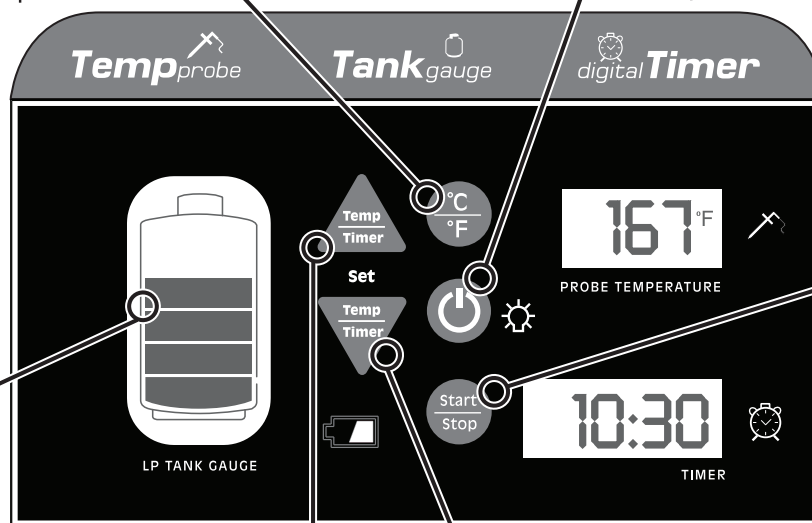

Start / Stop: To Start the timer function during cooking or to stop the timer function. Also, to reset the timer, hold down this button.





Up Temp / Timer: This button is used for setting the temperature variable and increasing temperature and timer. To set temperature, hold this button down for 3 seconds.

Down Temp / Timer: This button is used for setting the timer variable and decreasing the temperature and timer. To set timer, hold this button down for 3 seconds.

Thermometer

1. Temperature set-up value is from 0-499°C or 32-931°F.
2. When inputting temperature, if the buzzer sounds and LCD display begins to blink please re-set your temperature value ensuring that you have chosen the correct temperature measurement, and that the temperature is not set beyond the ranges shown in point 1.
3. When using the temperature probe always ensure that you are inserting into the thickest portion of the meat. If the buzzer sounds during use of the temperature probe this will indicate that either you have reached or gone beyond the set temperature. The buzzer will sound every 3 seconds.

Set Target Probe Temperature

1. To set target probe temperature, hold down the  for 3 seconds. This will activate the set mode.
2. Use the  and  to set desired temperature. The  is used to switch temperature digits.
3. Once complete, the unit will automatically exit the set mode.

Set Timer

1. To set the count down timer, hold down the  button for 3 seconds. This will activate the set mode.
2. Use the  and  to set the timer. The  is used to toggle between the minutes and seconds. The flashing digit is the one you are adjusting.

CARE AND CLEANING OF YOUR STAINLESS STEEL GRILL

Routine cleaning is necessary to preserve the appearance and corrosion resistance of Stainless Steel. The perception that many people have is that stainless steel will not rust. That is not the case in certain conditions. Rust marks are regular steel particles that have become attached to the surface of stainless steel. They may also occur if you are using a steel wool or wire wool scouring pad instead of a nylon scouring pad to clean your grill. In coastal areas, small rust pits may develop on the surface of your grill that cannot be fully removed by a cleaner. Concentrate bleaches and other solutions containing chlorine can also cause rust pits and should not be used.

Cooking creates smoke that may eventually coat and discolor the stainless steel surface. Grease fires will darken the stainless steel surface, but will not affect the integrity of the steel. Periodic cleaning of the cooking surface and inside of the grill helps decrease the risk of a fire. The methods below are suggestions for cleaning stainless steel surfaces. Choose a cleaning method appropriate for your needs. It is recommended that you use a Char-Broil® grill cover to help prolong the life and prevent discoloration of your grill.

Routine Care

After each use, let your grill cool and then wipe the grill with a soft, damp, soapy cloth and rinse with clean water. It is important to remove any food particles or marinade from the stainless steel surface of your grill. Most marinades are highly acidic and damage stainless steel. **DO NOT USE STEEL OR WIRE WOOL.** To clean, polish and protect your stainless steel grill on a weekly basis use Char-Broil® Stainless Steel Grill Cleaner. For quick, convenient cleaning, use Char-Broil® Stainless Steel Grill Wipes.

Stubborn Stains and Rust

Stubborn stains, discoloration and possibly rust and rust pitting can occur from cooking, exposure to harsh outdoor conditions, or extreme cooking temperatures. For stubborn rust stains and grease stains, you can restore your grill with the Char-Broil Stainless Steel Restoration Kit. It is available at major retailers or you can buy it online at www.charbroil.com or www.grilllovers.com. For the latest new products and information for the care and cleaning of your stainless steel grill go to www.charbroil.com.

* Always rub or wipe in the direction of the grain or polish lines in the stainless steel surface, not across them.

** Do not let stainless steel cleaners come in contact with painted or plastic surfaces as damage may occur.

ROUTINE CARE

Char-Broil® Stainless Steel
Grill Cleaner



ROUTINE CARE

Char-Broil® Stainless Steel
Grill Wipes



STUBBORN STAINS AND RUST

Char-Broil® Stainless Restoration Kit



PARTS LIST – Model No. 463250308

Key	Qty	Description	Part #
A	1	Bottom Shelf.....	80016693
B	2	Locking Caster.....	80000268
C	2	Fixed Caster.....	80004093
D	1	Downside Panel, Left.....	80016143
E	1	Downside Panel, Right.....	80016144
F	1	Electronic Ignitor Module.....	80007900
G	1	Battery Cap	80007380
H	1	Heat Shield, F/Firebox.....	80016196
I	1	Front Brace, Left, F/Cart.....	80016147
J	1	Front Brace, Right, F/Cart.....	80016148
K	1	Rear Panel, Down.....	80016163
L	1	Top Lid Assy.....	80016155
M	1	Top End Weldment, Left.....	80016114
N	1	Top End Weldment, Right.....	80016115
O	1	Fixed Plate, Lid Inner, Left.....	80016116
P	1	Fixed Plate, Lid Inner, Right.....	80016117
Q	1	Top Lid Inner.....	80016156
R	1	Logo Plate.....	80016119
S	1	Thermometer.....	80016193
T	2	Handle End, Top Lid.....	80016120
U	1	Handle, Top Lid	80007410
V	1	Burner Box Weldment, Main	80016157
W	1	Upside Panel Weldment, L, F/Firebox.	80005586
X	1	Upside Panel Weldment, R, F/Firebox.	80005585
Y	1	Upside Panel Weldment, L, F/Cart....	80016124
Z	1	Upside Panel Weldment, R, F/Cart...	80016890
AA	1	Electrode, Middle, F/main burner....	80016128
BB	1	Hose/Valve/Regulator.....	80016160
CC	1	Control Panel, Main.....	80016161
DD	4	Bezel, F/main burner.....	80016131
EE	1	Back Burner Brace Weldment.....	80016158
FF	4	Burner Assy, Main Burner.....	80016159
GG	5	Control Knob	80007319
HH	2	Match Holder.....	80006579
II	2	Grommet, F/Regulator Hole.....	80006386
JJ	1	Up Door Brace Assy.....	80016168
KK	4	Cooking Grate, F/Main burner.....	80007320
LL	1	Rear Panel Upper, F/Cart.....	80016162
MM	1	Side burner Fascia, Side Burner.....	80016172
NN	1	Drip Pan Insert.....	80005654
OO	1	Side burner shelf weldment.....	80016171
PP	1	Electrode Pole, Side Burner.....	80016174
QQ	1	Lid, Side Burner.....	80016175
RR	1	Side Burner	80004311
SS	1	Bezel, F/Side burner.....	80016200

Key	Qty	Description	Part #
TT	1	Wind Diverter	80005038
UU	1	Side Shelf Weldment.....	80016176
VV	1	Drawer Assy, Side Shelf.....	80016177
WW	1	Towel Bar, Side shelf Weldment.....	80016813
XX	1	Heat Shield, F/Tank.....	80016164
YY	1	Door Assy, Left.....	80016169
ZZ	1	Door Assy, Right.....	80016170
AAA	2	Handle Tube, F/Door.....	80007337
BBB	6	Handle End, F/Door.....	80016141
CCC	1	Condiment Tray, Door	80000266
DDD	2	Trough Assy.....	80007874
EEE	1	Trough Middle	80007884
FFF	3	Magnet Assy.....	80008850
GGG	1	Swing away.....	80007753
HHH	1	Grate, side burner	80003591
III	1	Griddle, Side burner.....	80003592
JJJ	1	Handle, Side burner Lid.....	80007365
KKK	1	Tank Gauge.....	80016179
LLL	1	Tank Shelf Assy.....	80016166
MMM	2	Electrode, F/side, F/main burner....	80016191
NNN	1	Electrode, third, F/main burner.....	80016198
OOO	1	Wire, side burner.....	80001404
PPP	1	Handle, drawer.....	80016180
QQQ	1	Ground wire.....	80001400
RRR	1	Display Screen F/Tank gauge	80016689
TTT	1	Hing Assy, F/Sideburner lid.....	80017109
Not Pictured			
	1	Product Guide (English).....	80015527
	1	Product Guide (Spanish).....	80015528
	1	Sideburner Repair Kit, F/Red.....	80017150
	1	Hardware Pack(for retailer only).....	80016181
	2	#1/4-20x1-1/2" Machine Screws	
	7	#1/4-20x1/2" Machine Screws	
	13	#1/4" Lock Washers, 7MM	
	13	#1/4" Flat Washers, 7MM	
	2	#10-24x3/8" Machine Screws	
	2	#10 Lock Washers, 5mm	
	2	#10 Fibre Washer, 5mm	
	6	#8-32x3/8 Machine Screws	
	6	#8 Lock Washers, 4MM	
	4	#8 Flat Washers, 4MM	
	4	#8 Hex Nuts	
	2	#5-40X1/5" Machine Screws	
	2	#1/4-20x3/4" Machine Screws	
	1	Control Knob	
	1	Bezel, F/Control Knob	
	1	Clip, F/sideburner	
	1	AA Battery	

Tools required for assembly:

Caster Wrench - Provided • Phillips screwdriver - Not provided

Estimated assembly time: 30-45 minutes

NOTE: Some grill parts shown in the assembly steps may differ slightly in appearance from those on your particular grill model. However, the method of assembly remains the same.

PARTS DIAGRAM – Model No. 463250308

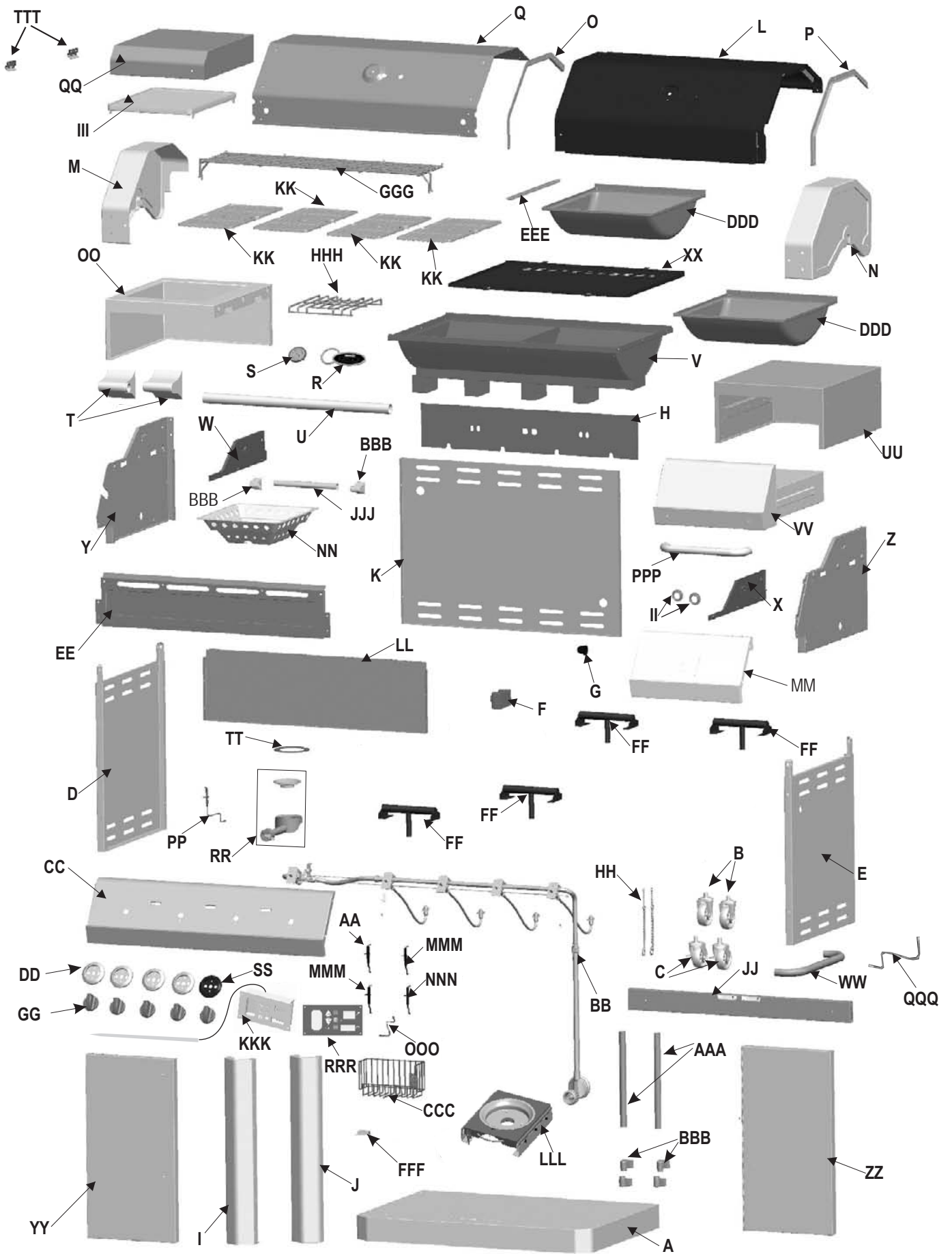

ASSEMBLY – Model 463250308

1

Right Shelf Handle and Drawer handle Assembly

- Draw the **Drawer** out of the **right side shelf**, make sure using your two hands and push the lock in right directions shown **A B** and **C**.
- Attach **towel bar** to **right side shelf** using two **1/4-20x3/4"** screws, **1/4"** lock washer and **1/4"** flat washers shown **D**.



B Left side of the drawer

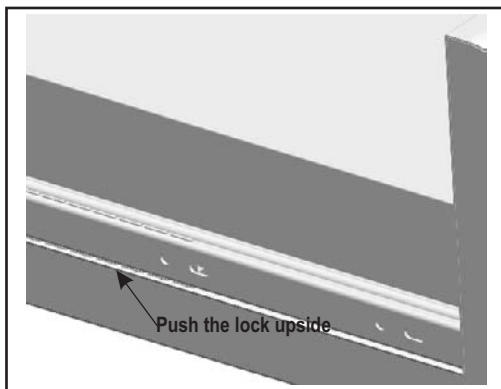

C Right side of the drawer

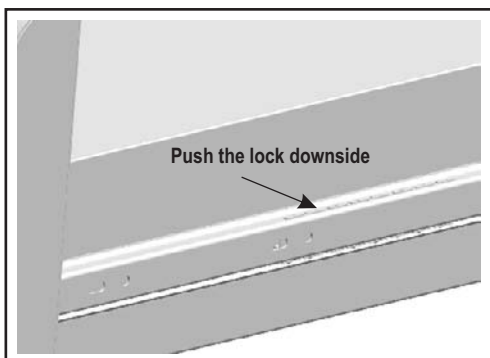

A

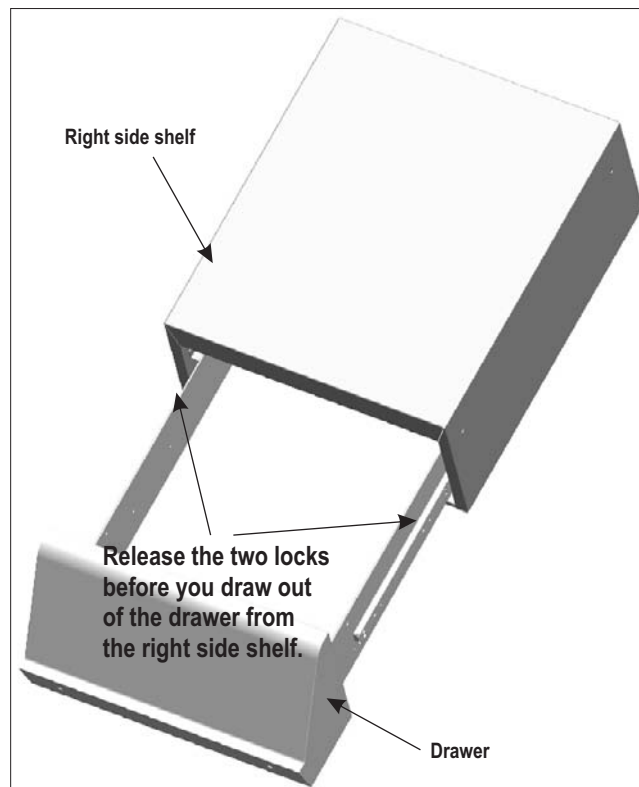

D

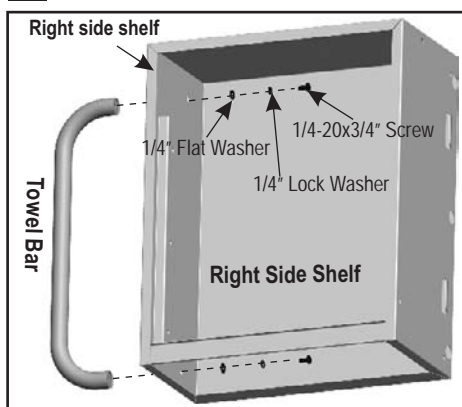

2

Right and Left Shelf Assembly

- Insert **right side shelf** over screws and washers through bracket shown **A**, make sure insert **tabs** into **cut-outs** and **holes** into **bulges** properly.
- Attach **right side shelf** onto **right side panel** using one **1/4-20x1-1/2"** screw, three **1/4-20x1/2"** screw, four **1/4"** flat washers and four **1/4"** lock washers shown **B**.
- Insert the **Drawer** into the **right side shelf** shown **C**.
- Insert **side burner shelf** over screws and washers through bracket similar to right side shelf, make sure insert **tabs** into **cut-outs** and **holes** into **bulges** properly.
- Attach **side burner shelf** onto **left side panel** using one **1/4-20x1/2"** screws, one **1/4-20x1-1/2"** screw, two **1/4"** lock washers and two **1/4"** flat washers at the rear of shelf shown **D**; Using three **1/4-20x1/2"** screw, **1/4"** lock washers and **1/4"** flat washers at front of the shelf shown **E**.
- Attach **side burner lid** onto **side burner shelf** using four **#8-32x3/8"** screws, **#8** lock washers, **#8** flat washers and **#8** Hex Nuts shown **F**.

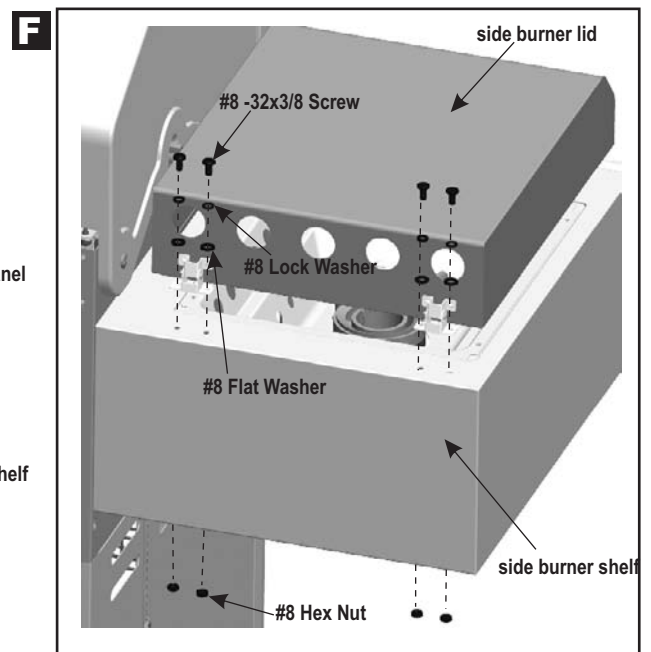
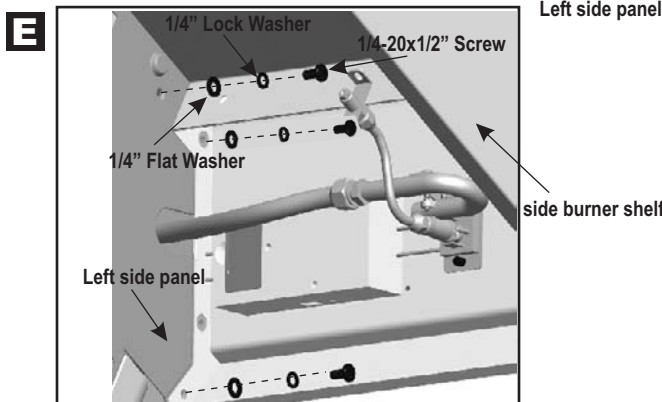
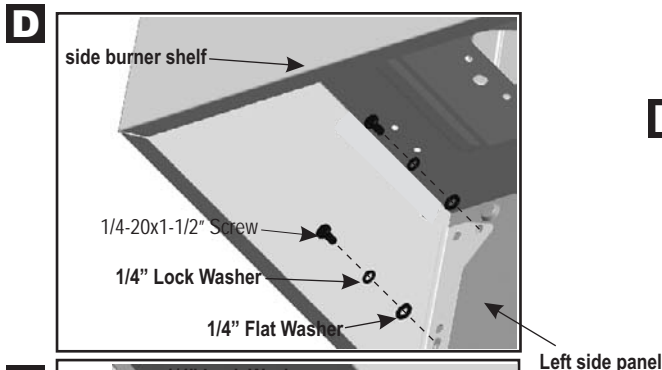
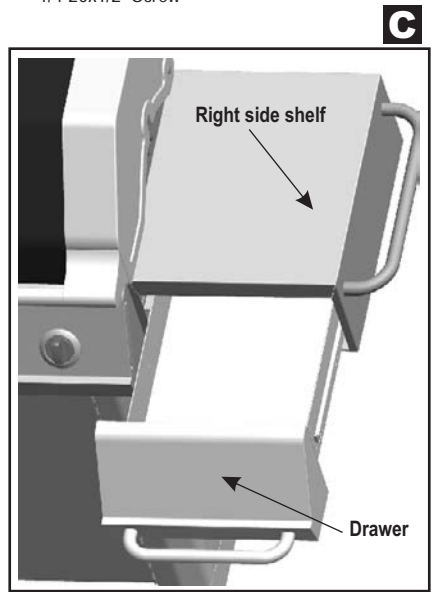
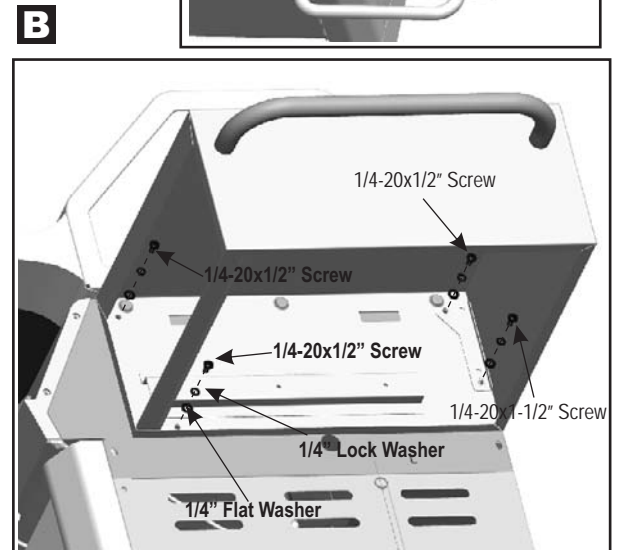
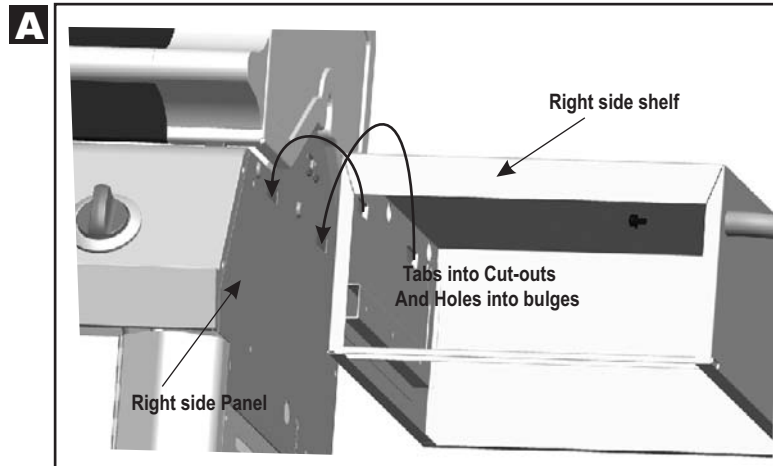
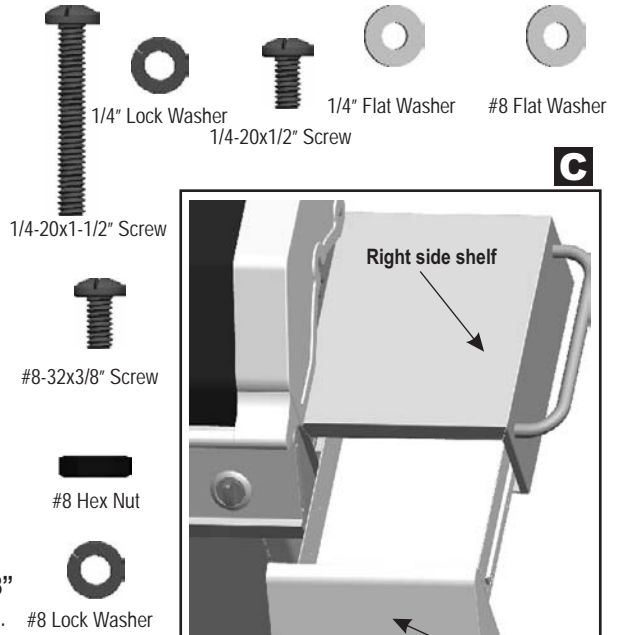

3

Tank Gauge Assembly

- First, secure **temperature probe** the **clamp** on the left side panel show **A**.
- Make the **gauge wire** go through the hole on the left side shelf and insert to the tank gauge show **B** and **C**.

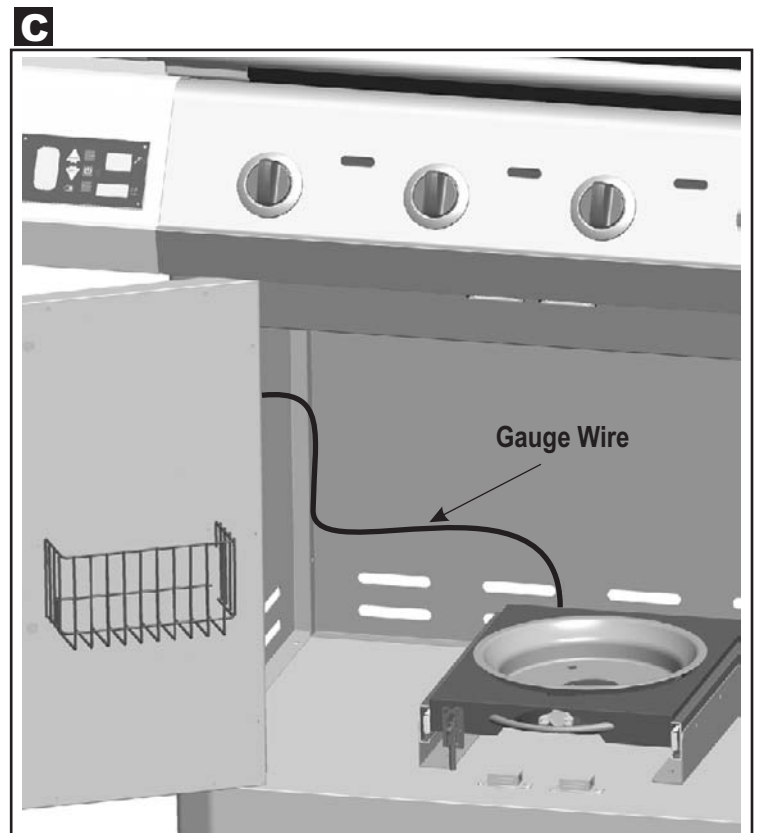
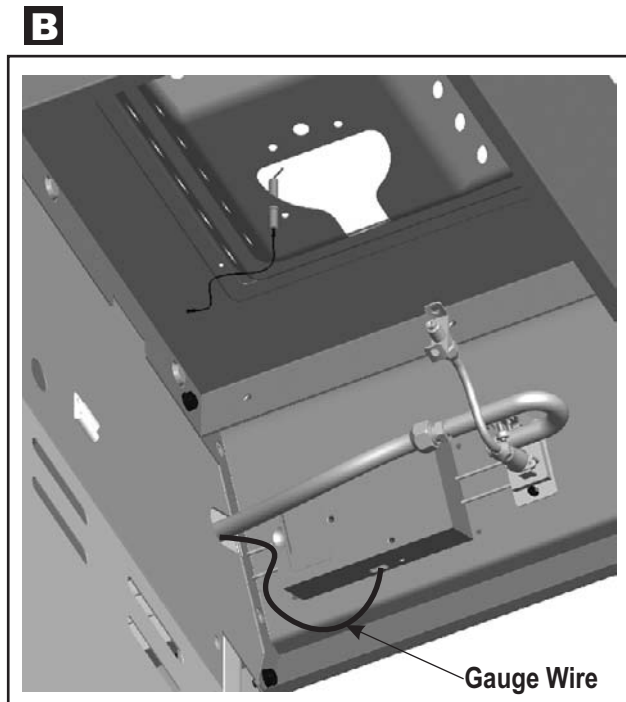
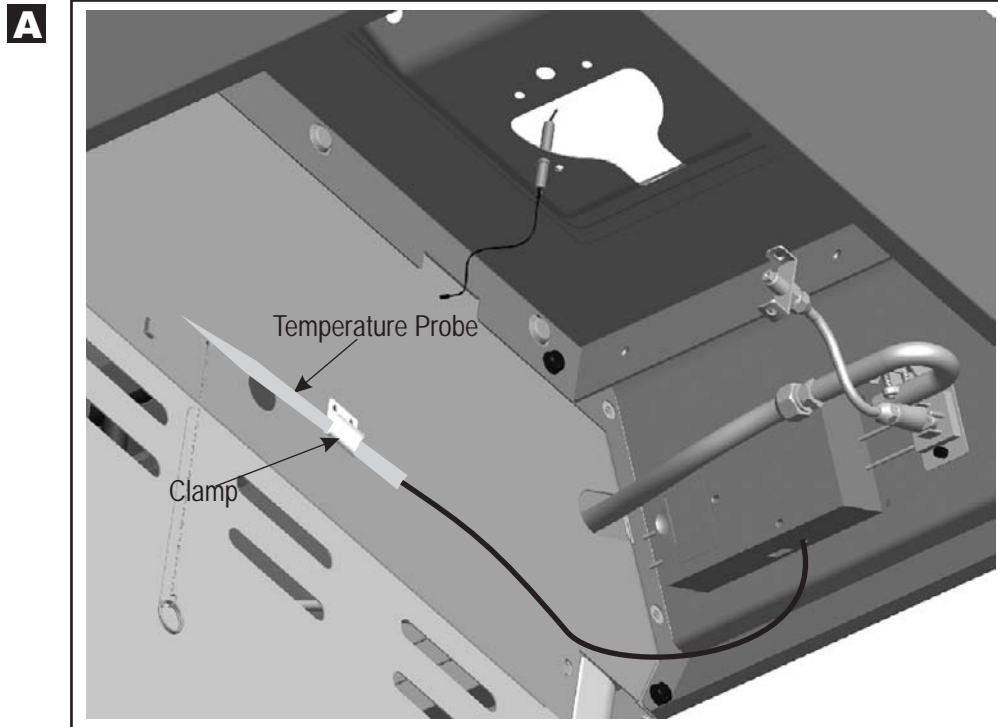

4 Side Burner Assembly

- Insert the side burner valve into the side burner and secure it to the bracket using two **#5-40x1/5"** screws shown **A**.
- Make sure burner tube aligns correctly onto side burner valve underneath left shelf shown **B**.
- Insert back of side burner through left shelf cut-out shown **C**, reverse 180° after go through the cut-out and make center stud on bottom rear of burner fits into center hole in burner pan on left shelf.
- Secure burner to pan using two **#10-24x3/8"** screws and **5mm** silicon washer and **#10** lock washers shown **D**.
- Attach side burner igniter wire from igniter module to electrode tip underneath left shelf shown **E**.



A

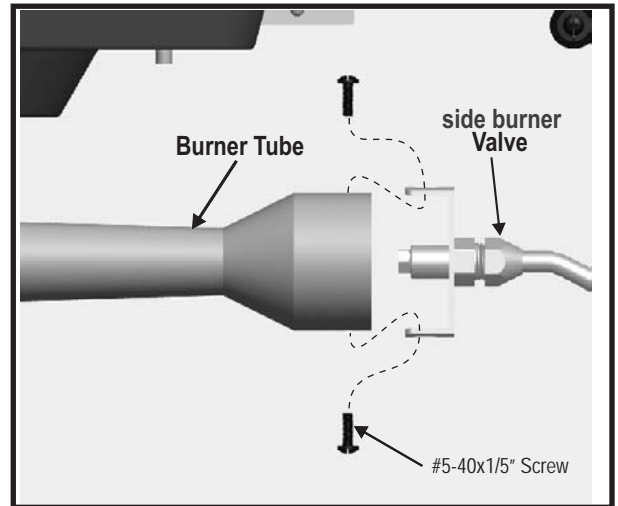

B

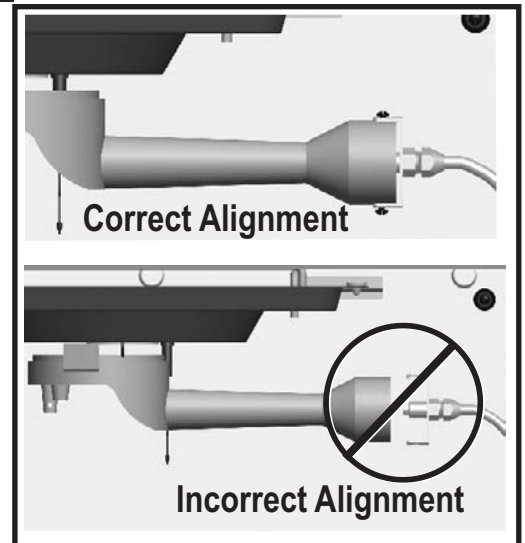

C

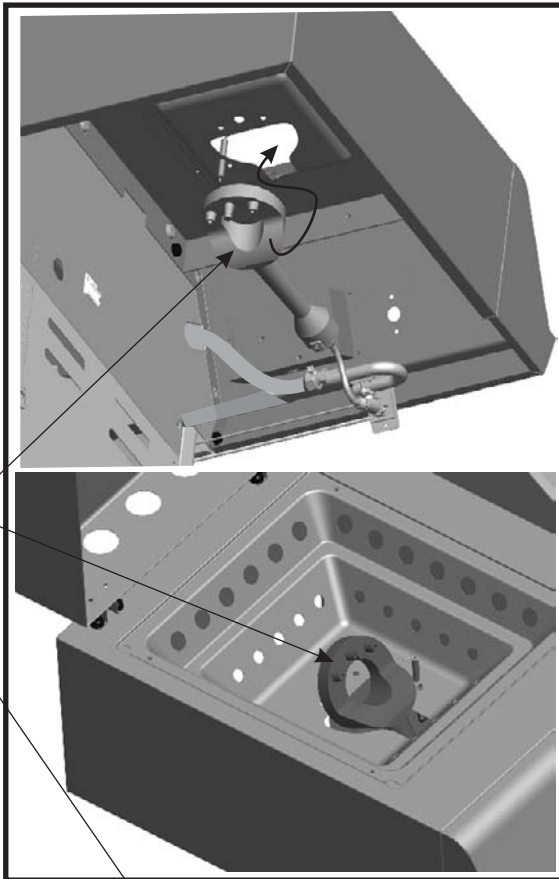

This surface turn over 180° and insert into cut-out then turn back when locating onto the the bracket.

D

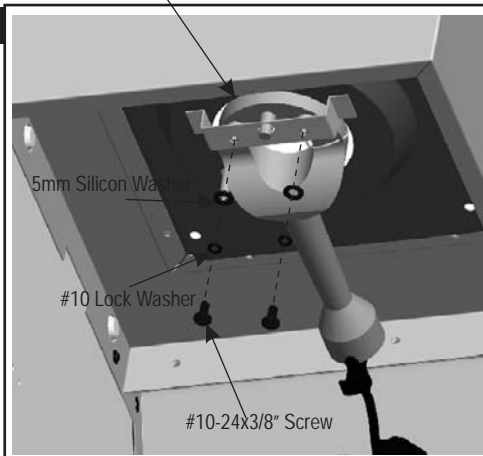

E

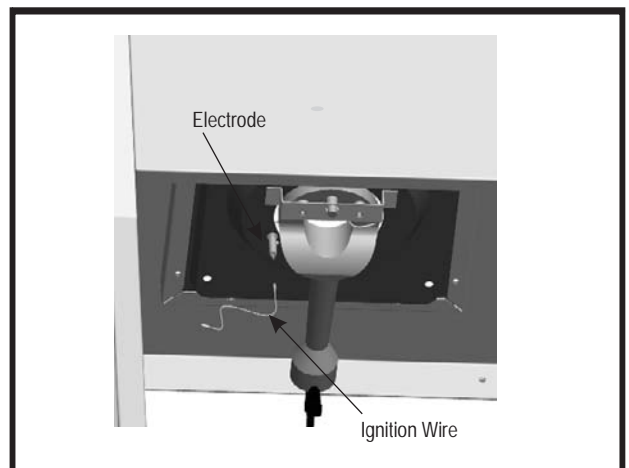

5

side burner Control Knob Assembly

- Position side burner valve bracket beneath side burner shelf fascia so that valve stem comes through larger center hole in fascia shown **A**.
- Attach side burner bezel to fascia using two **#8-32x3/8"** screws and **#8** lock washers shown **A**.
- Press side burner control knob onto valve stem shown **A**.



Note: Make sure place the Bezel with longer slot at the top.

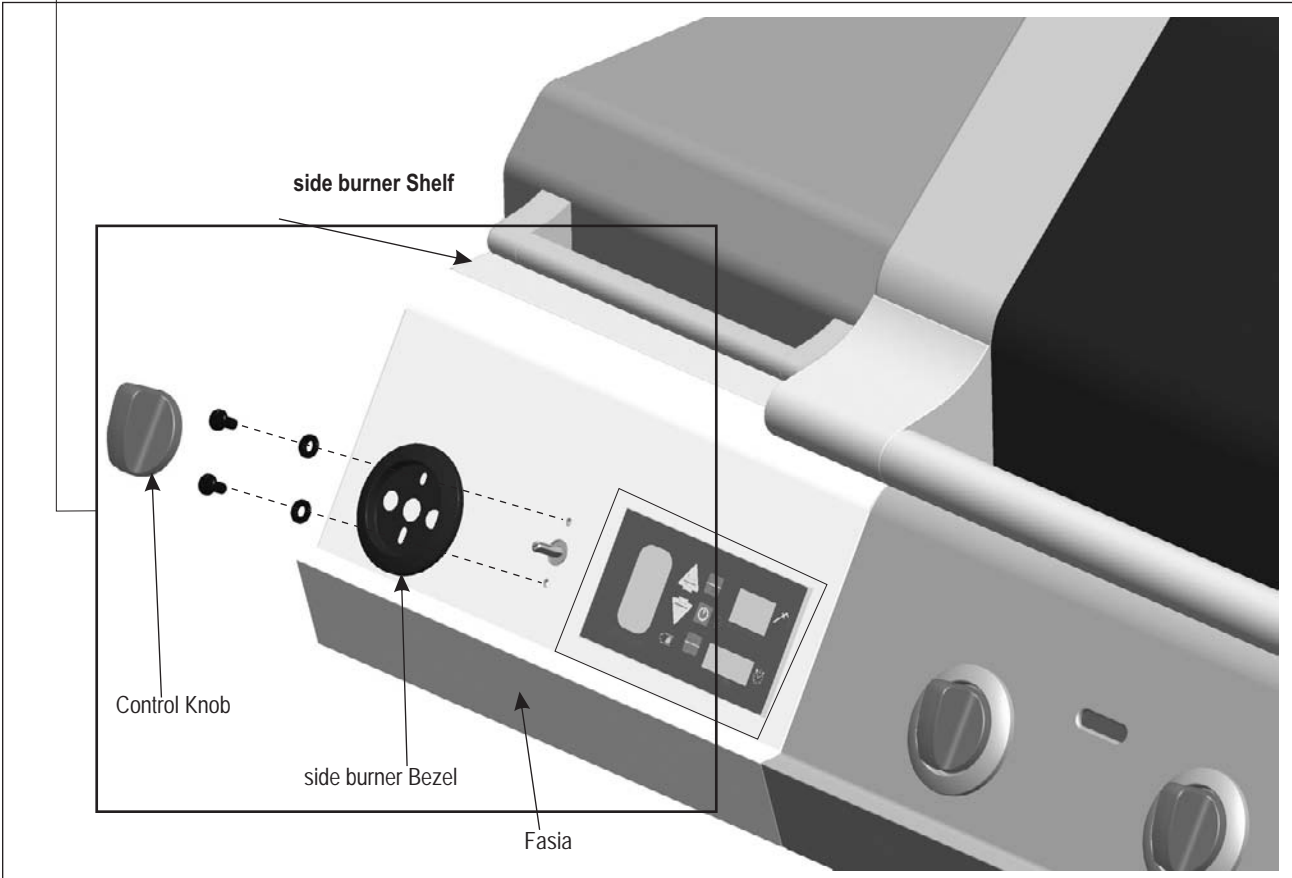
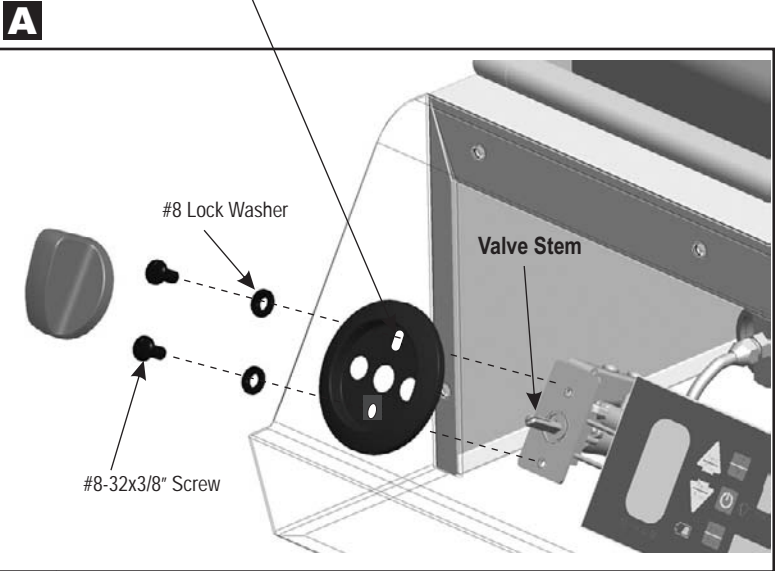

6

Side burner Wind Diverter, Side burner Cap and Clip, side burner Grate, Griddle

- Place side burner wind **diverter** over side burner aligning cut-out
- Place **burner cap** onto side burner and attach side burner cap clip shown **B**.
- Place **side burner cooking grate** onto side burner shelf, aligning grate legs with holes in shelf shown **A**.
- Place **griddle** onto side burner shelf shown **A**.



Clip

A

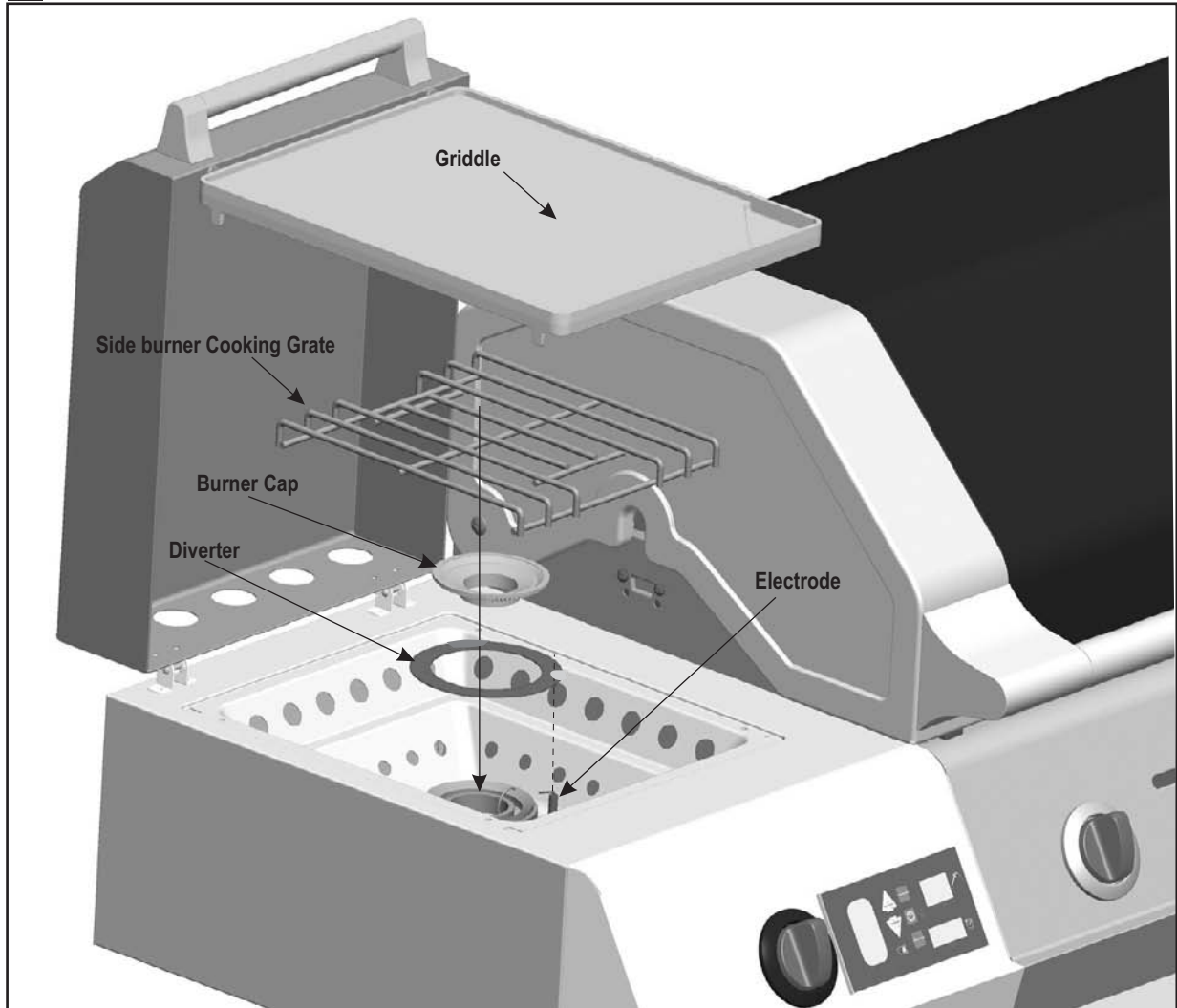

B

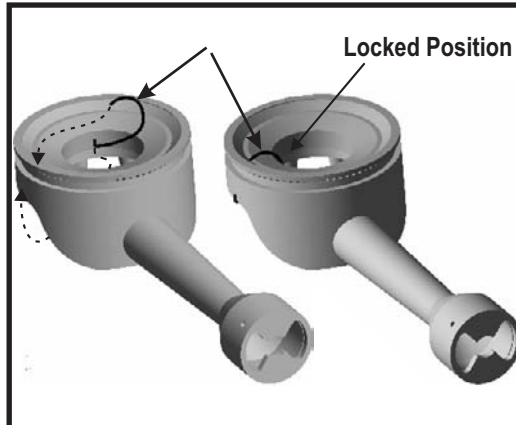

7

Trough Install

- First, place **Trough Middle** onto Firebox show **A**.
- Second, place two **Trough Assy** onto Firebox. **Make sure this is put in the right direction as show in B.**

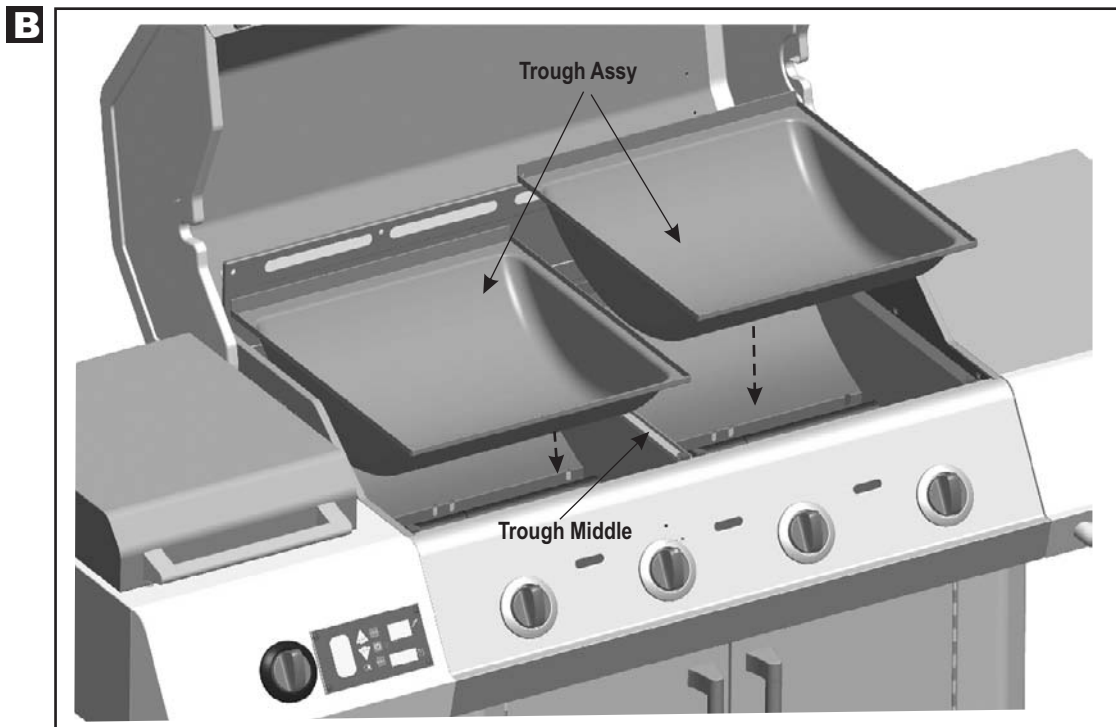
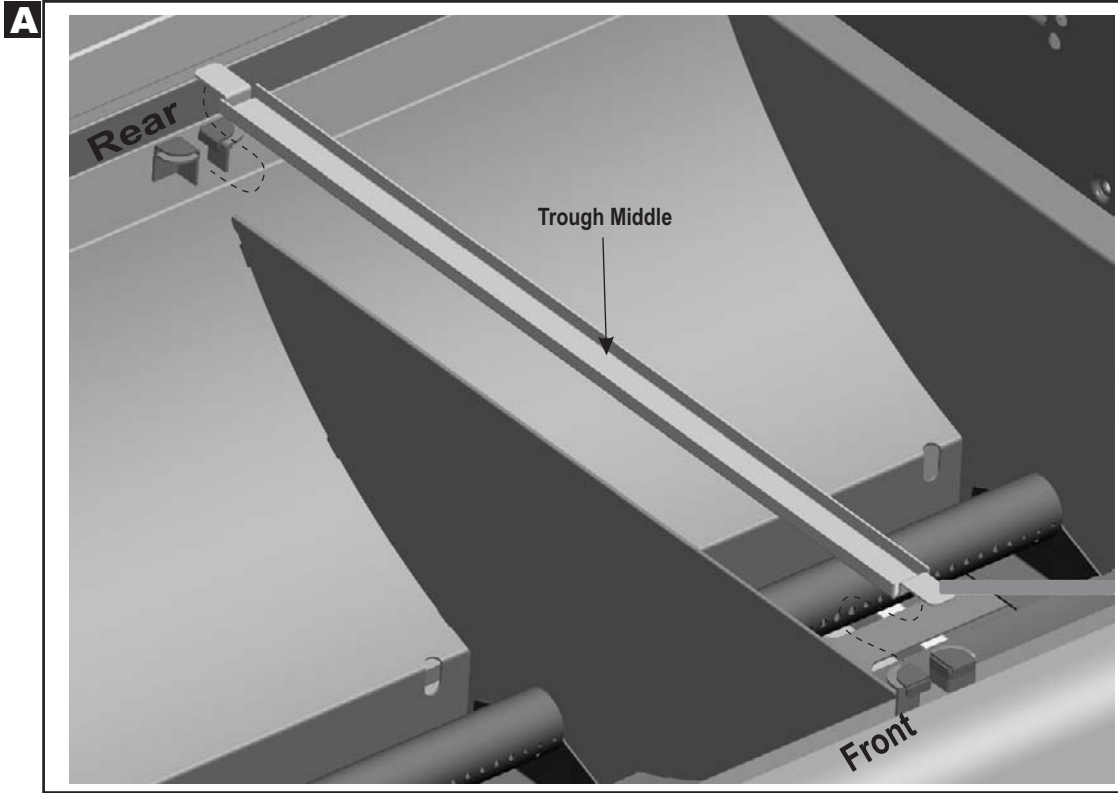

8

Cooking Grate and Swing away

- Place **cooking grates** onto the firebox as shown.
- Place the **Swing away** onto the the firebox. Make sure insert the Swing away ends into the holes properly shown as below.

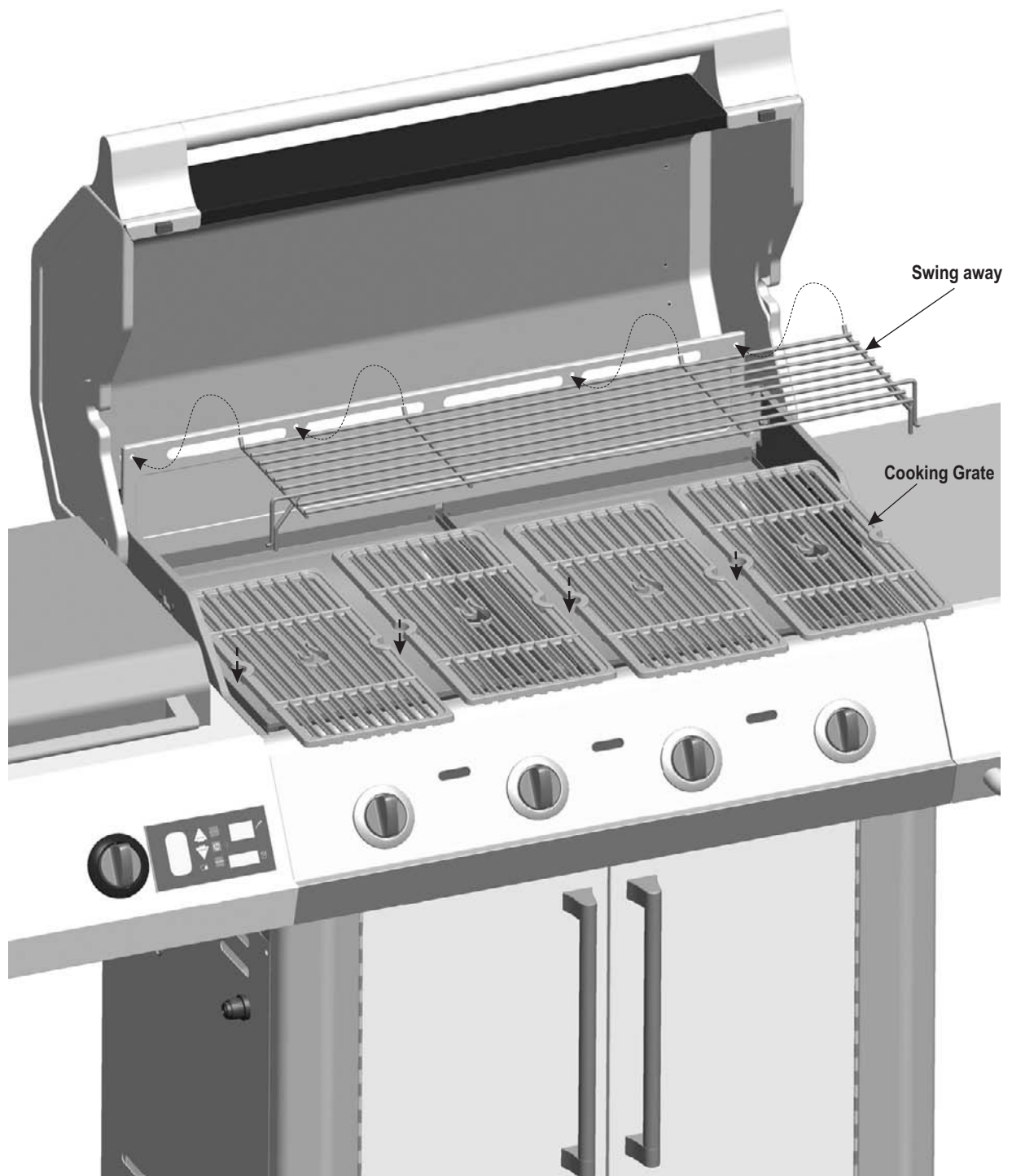

12 LP Tank

- **LP TANK IS SOLD SEPARATELY.** Fill and leak check the tank before attaching to grill and regulator (see Use & Care section).
- Once tank has been filled and leak checked, place cylinder into the tank tray in bottom shelf. **Make sure tank valve is facing front of grill.**
- Secure tank with tank screw under bottom shelf. Insert regulator through large hole in left side panel. **See Use & Care section of this manual to perform the "Burner Flame Check" and for important safety instructions before using.**

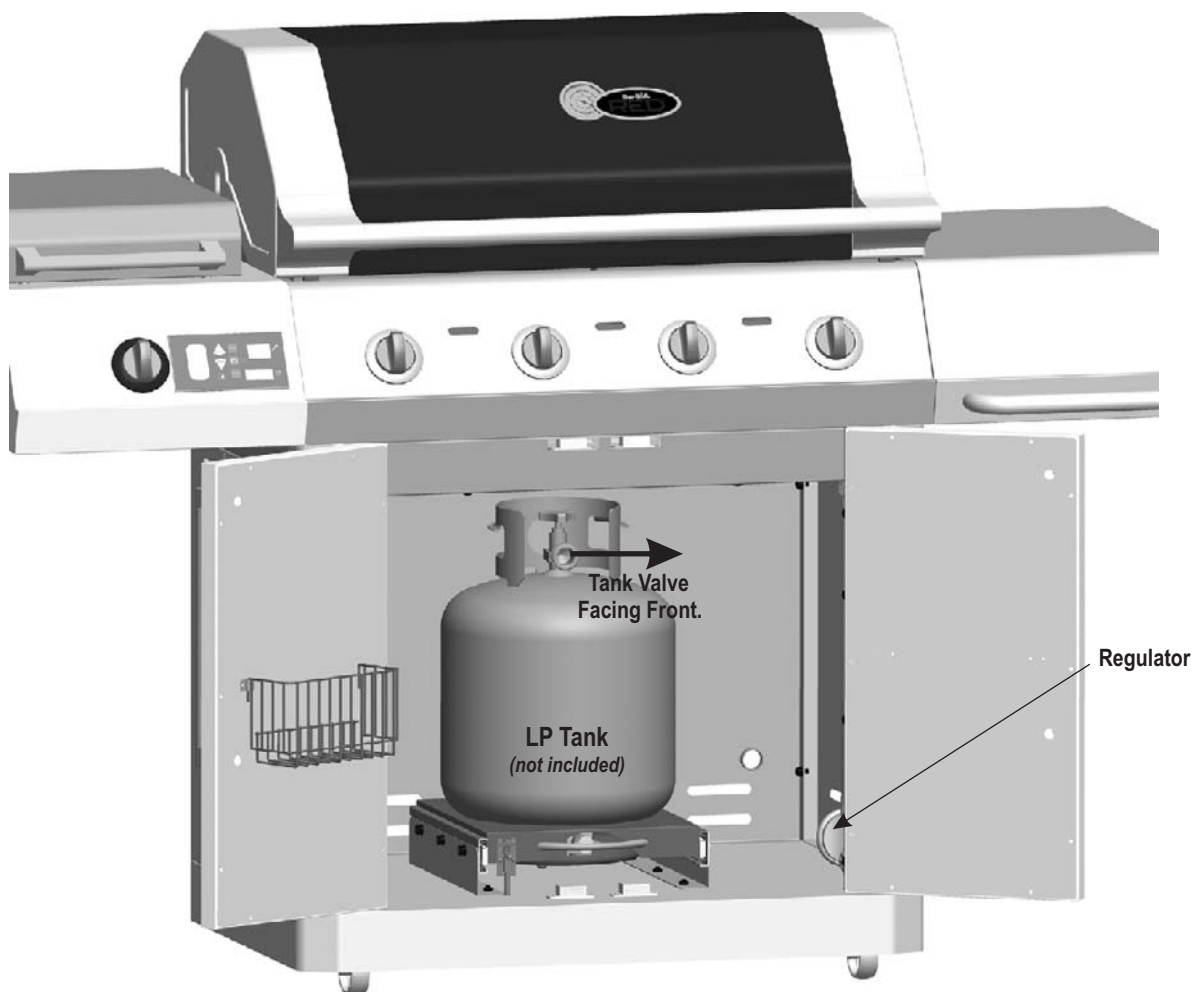

Tank Screw at bottom of slide bracket

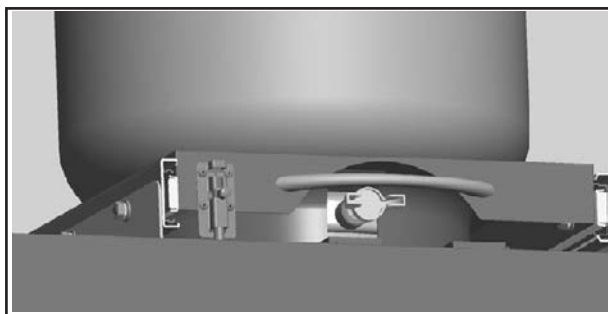

Always keep LP tank in upright position during use, transport, and storage.



LP Tank valve must face to front of cart once tank is attached. Failure to install cylinder correctly may allow gas hose to be damaged in operation, resulting in the risk of fire.

13

Electronic Ignition

- Unscrew electronic ignition cap on left side panel. Insert **AA** battery into ignitor, **negative (—) end first**. Replace button.

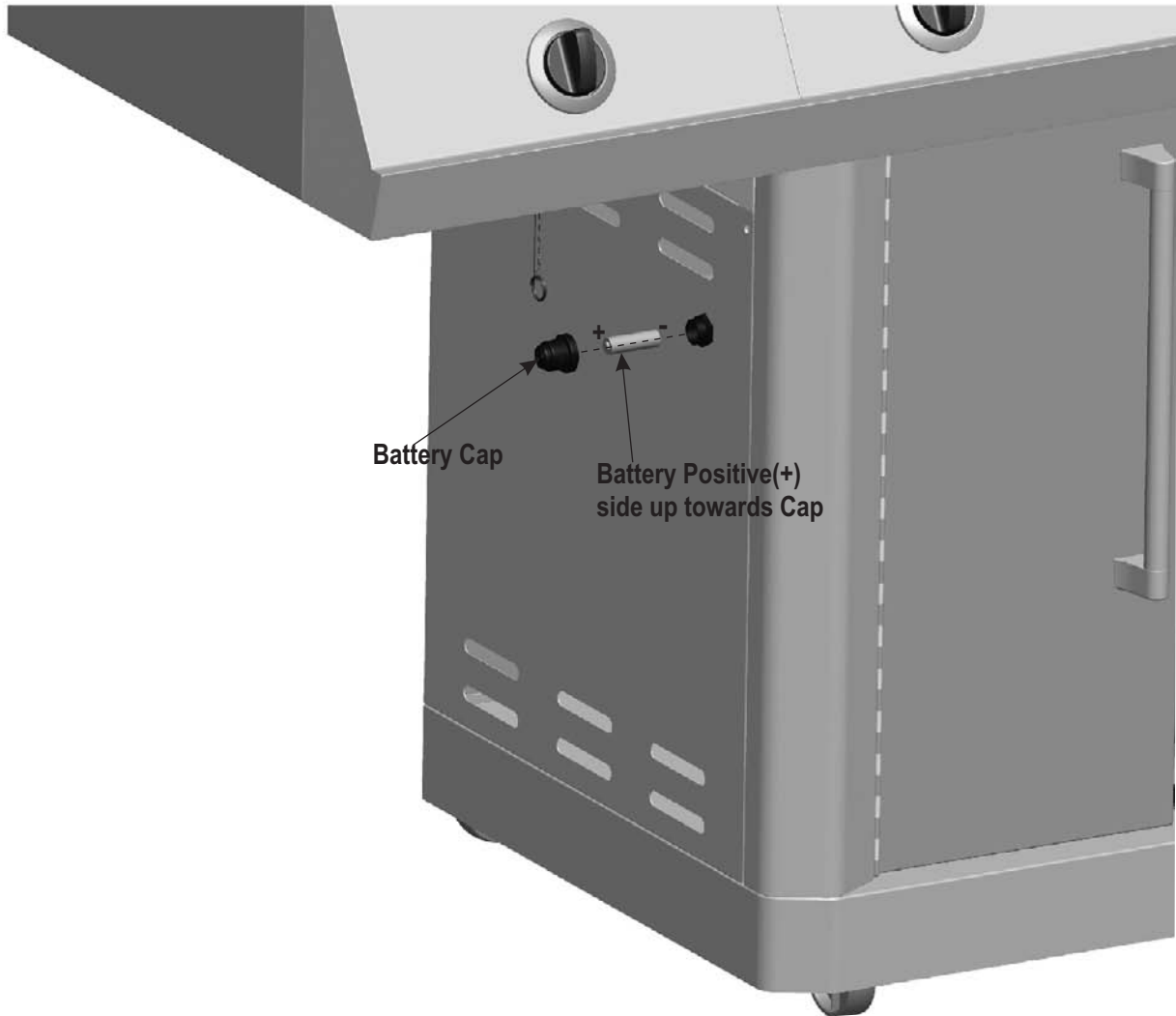

EMERGENCIES: If a gas leak cannot be stopped, or a fire occurs due to gas leakage, call the fire department.



Emergencies	Possible Cause	Prevention/Solution
Gas leaking from cracked/cut/burned hose.	• Damaged hose.	• Turn off gas at LP cylinder or at source on natural gas systems. If anything but burned, replace valve/hose/regulator. If burned, discontinue use of product until a plumber has investigated cause and corrections are made.
Gas leaking from LP cylinder.	• Mechanical failure due to rusting or mishandling.	• Replace LP cylinder.
Gas leaking from LP cylinder valve.	• Failure of cylinder valve from mishandling or mechanical failure.	• Turn off LP cylinder valve. Return LP cylinder to gas supplier.
Gas leaking between LP cylinder and regulator connection.	• Improper installation, connection not tight, failure of rubber seal.	• Turn off LP cylinder valve. Remove regulator from cylinder and visually inspect rubber seal for damage. See LP Cylinder Leak Test and Connecting Regulator to the LP Cylinder.
Fire coming through control panel.	• Fire in burner tube section of burner due to blockage.	• Turn off control knobs and LP cylinder valve. Leave lid open to allow flames to die down. After fire is out and grill is cold, remove burner and inspect for spider nests or rust. See Natural Hazard and Cleaning the Burner Assembly pages.
Grease fire or continuous excessive flames above cooking surface.	• Too much grease buildup in burner area.	• Turn off control knobs and LP cylinder valve. Leave lid open to allow flames to die down. After cooling, clean food particles and excess grease from inside firebox area, grease tray, and other surfaces.

Troubleshooting

Problem	Possible Cause	Prevention/Solution
<p>Burner(s) will not light using ignitor. (See Electronic Ignition Troubleshooting also)</p> <p><i>Continued on next page.</i></p>	<p>GAS ISSUES:</p> <ul style="list-style-type: none"> • Trying to light wrong burner. • Burner not engaged with control valve. • Obstruction in burner. • No gas flow. • Vapor lock at coupling nut to LP cylinder. • Coupling nut and LP cylinder valve not fully connected. <p>ELECTRICAL ISSUES:</p> <ul style="list-style-type: none"> • Electrode cracked or broken; "sparks at crack." • Electrode tip not in proper position. • Wire and/or electrode covered with cooking residue. • Wires are loose or disconnected. • Wires are shorting (sparking) between ignitor and electrode. • Dead battery. 	<ul style="list-style-type: none"> • See instructions on control panel and in Use and Care section. • Make sure valves are positioned inside of burner tubes. • Ensure burner tubes are not obstructed with spider webs or other matter. See cleaning section of Use and Care. • Make sure LP cylinder is not empty. If LP cylinder is not empty, refer to "Sudden drop in gas flow." • Turn off knobs and disconnect coupling nut from LP cylinder. Reconnect and retry. • Turn the coupling nut approximately one-half to three-quarters additional turn until solid stop. Tighten by hand only - do not use tools. • Replace electrode(s). <p>Main Burners:</p> <ul style="list-style-type: none"> • Tip of electrode should be pointing toward gas port opening on burner. The distance should be 1/8" to 1/4". Adjust if necessary. • Tip of electrode should be pointing toward gas port opening on side burner. The distance should be 1/8" to 3/16". Adjust if necessary. <ul style="list-style-type: none"> • Clean wire and/or electrode with rubbing alcohol and clean swab. • Reconnect wires or replace electrode/wire assembly. • Replace ignitor wire/electrode assembly. • Replace with a new AA-size alkaline battery.

<p>Burner(s) will not light using ignitor. (See Electronic Ignition Troubleshooting also)</p> <p>Burner(s) will not match light.</p> <p>Sudden drop in gas flow or low flame.</p>	<p>ELECTRONIC IGNITION:</p> <ul style="list-style-type: none"> •No spark, no ignition noise. •No spark, some ignition noise. •Sparks, but not at electrode or at full strength. <p>•See “GAS ISSUES:” on previous page.</p> <ul style="list-style-type: none"> •Match will not reach. •Improper method of match-lighting. <p>•Out of gas.</p> <ul style="list-style-type: none"> •Excess flow valve tripped. <p>•Vapor lock at coupling nut/LP cylinder connection.</p>	<ul style="list-style-type: none"> • See Section I of Electronic Ignition System. • See Section II of Electronic Ignition System. • See Section III of Electronic Ignition System. <p>•Use long-stem match (fireplace match).</p> <p>•See “Match-Lighting” section of Use and Care.</p> <p>•Check for gas in LP cylinder.</p> <ul style="list-style-type: none"> •Turn off knobs, wait 30 seconds and light grill. If flames are still low, turn off knobs and LP cylinder valve. Disconnect regulator. Reconnect regulator and leak-test. Turn on LP cylinder valve, wait 30 seconds and then light grill. •Turn off knobs and LP cylinder valve. Disconnect coupling nut from cylinder. Reconnect and retry.
<p>Flames blow out.</p>	<ul style="list-style-type: none"> •High or gusting winds. •Low on LP gas. •Excess flow valve tripped. 	<ul style="list-style-type: none"> •Turn front of grill to face wind or increase flame height. •Refill LP cylinder. •Refer to “Sudden drop in gas flow” above.
<p>Flare-up.</p>	<ul style="list-style-type: none"> •Grease buildup. •Excessive fat in meat. •Excessive cooking temperature. 	<ul style="list-style-type: none"> •Clean burners and inside of grill/firebox. •Trim fat from meat before grilling. •Adjust (lower) temperature accordingly.
<p>Persistent grease fire.</p>	<ul style="list-style-type: none"> •Grease trapped by food buildup around burner system. 	<ul style="list-style-type: none"> •Turn knobs to OFF. Turn gas off at LP cylinder. Leave lid in position and let fire burn out. After grill cools, remove and clean all parts.
<p>Flashback... (fire in burner tube(s)).</p>	<ul style="list-style-type: none"> •Burner and/or burner tubes are blocked. 	<ul style="list-style-type: none"> •Turn knobs to OFF. Clean burner and/or burner tubes. See burner cleaning section of Use and Care.
<p>Unable to fill LP cylinder.</p>	<ul style="list-style-type: none"> •Some dealers have older fill nozzles with worn threads. 	<ul style="list-style-type: none"> •The worn nozzles don't have enough “bite” to engage the valve. Try a second LP dealer.
<p>One burner does not light from other burner(s).</p>	<ul style="list-style-type: none"> •Grease buildup or food particles in end(s) of carryover tube(s). 	<ul style="list-style-type: none"> •Clean carry-over tube(s) with wire brush.

Troubleshooting - Electronic Ignition

Problem (Ignition)	Possible Cause	Check Procedure	Prevention/Solution
<p>SECTION I No sparks appear at any electrodes when control knob turned to ; no noise can be heard from spark module.</p>	<ul style="list-style-type: none"> •Battery not installed properly. •Dead battery. •Faulty spark module. 	<ul style="list-style-type: none"> •Check battery orientation. •Has battery been used previously? •If no sparks are generated with new battery and good wire connections, module is faulty. 	<ul style="list-style-type: none"> •Install battery (make sure that "+" and "-" connectors are oriented correctly, with "+" end up and "-" end down.) •Replace battery with new AA-size alkaline battery. •Replace spark module assembly.
<p>SECTION II No sparks appear at any electrodes when control knob turned to ; noise can be heard from spark module.</p>	<ul style="list-style-type: none"> •Output lead connections not connected. 	<ul style="list-style-type: none"> •Are output connections on and tight? 	<ul style="list-style-type: none"> •Remove and reconnect all output connections at module and electrodes.
<p>SECTION III Sparks are present but not at all electrodes and/or not at full strength</p>	<ul style="list-style-type: none"> •Output lead connections not connected. •Arcing to grill away from burner(s). •Weak battery. •Electrodes are wet. •Electrodes cracked or broken "sparks at crack". •Faulty knob ignition switches. 	<ul style="list-style-type: none"> •Are output connections on and tight? •If possible, observe grill in dark location. Operate ignition system and look for arcing between output wires and grill frame. •All sparks present but weak or at slow rate. •Has moisture accumulated on electrode and/or in burner ports? •Inspect electrodes for cracks. •If all of the other trouble shooting procedures listed above did not solve the problem, it is likely that the knob ignition switch is faulty. 	<ul style="list-style-type: none"> •Remove and reconnect all output connections at module and electrodes. •If sparks are observed other than from burner(s), wire insulation may be damaged. Replace wires. •Replace battery with a new AA-size alkaline battery. •Use paper towel to remove moisture. •Replace cracked or broken electrodes. •Replace ignition switch/valve assembly.

LIMITED WARRANTY

Manufacturer warrants to the original consumer-purchaser only that this product shall be free from defects in workmanship and materials after correct assembly and under normal and reasonable home use for the periods indicated below beginning on the date of purchase.

The manufacturer reserves the right to require that defective parts be returned, postage and or freight pre-paid, by the consumer, for review and examination.

LIMITED warranty against perforation, manufacturing and materials defects ONLY.

Electronics - 1 year

Remaining parts - 2 years

Upon consumer supplying proof of purchase as provided herein, Manufacturer will repair or replace the parts listed below which are proven defective during the applicable warranty period. Parts required to complete such repair or replacement shall be free of charge to you except for shipping costs. **The original consumer-purchaser will be responsible for all shipping charges of parts replaced under the terms of this limited warranty.**

This limited warranty is applicable in the United States and Canada only, is only available to the original owner of the product and is not transferable. Manufacturer requires reasonable proof of your date of purchase. Therefore, you should retain your sales slip or invoice and register your new product immediately. Defective or missing parts subject to this limited warranty will not be replaced without registration or proof of purchase. Register online at <http://www.charbroil.com> or complete and return via mail the Product Registration Card located on the last page of the Use & Care manual included with this product and retain your sales receipt for proof of purchase.

This limited warranty applies to the functionality of the product ONLY and does not cover cosmetic issues such as scratches, dents, corruptions or discoloring by heat, abrasive and chemical cleaners or any tools used in the assembly or installation of the appliance, surface rust, or the discoloration of stainless steel surfaces.

This limited warranty will not reimburse you for the cost of any inconvenience, food, personal injury or property damage.

If an original replacement part is not available, a comparable replacement part will be sent. You will be responsible for all shipping charges of parts replaced under the terms of this limited warranty.

ITEMS MANUFACTURER WILL NOT PAY FOR:

1. Service calls to your home.
2. Repairs when your product is used for other than normal, single-family household or residential use.
3. Damage resulting from accident, alteration, misuse, abuse, fire, flood, acts of God, improper installation, installation not in accordance with electrical or plumbing codes, or use of products not approved by the manufacturer.
4. Any food loss due to product failures.
5. Replacement parts or repair labor costs for units operated outside the United States or Canada.
6. Pickup and delivery of your product.
7. Repairs to parts or systems resulting from unauthorized modifications made to the product.
8. The removal and/or reinstallation of your product.
9. Shipping cost, standard or expedited, for warranty and replacement parts.

DISCLAIMER OF IMPLIED WARRANTIES; LIMITATION OF REMEDIES

Repair or replacement of defect parts is your exclusive remedy under the terms of this limited warranty. Manufacturer will not be responsible for any consequential or incidental damages arising from the breach of either this limited warranty or any applicable warranty, or for failure or damage resulting from acts of God, improper care and maintenance, grease fire, accident, alteration, replacement of parts by anyone other than Manufacturer, misuse, transportation, commercial use, abuse, hostile environments (inclement weather, acts of nature, animal tampering), improper installation or installation not in accordance with local codes or printed manufacturer instructions.

THIS LIMITED WARRANTY IS THE SOLE EXPRESS WARRANTY GIVEN BY THE MANUFACTURER. NO PRODUCT PERFORMANCE SPECIFICATION OR DESCRIPTION WHEREVER APPEARING IS WARRANTED BY MANUFACTURER EXCEPT TO THE EXTENT SET FORTH IN THIS LIMITED WARRANTY. ANY IMPLIED WARRANTY PROTECTION ARISING UNDER THE LAWS OF ANY STATE, INCLUDING IMPLIED WARRANTY OF MERCHANTABILITY OR FITNESS FOR A PARTICULAR PURPOSE OR USE, IS HEREBY LIMITED IN DURATION TO THE DURATION OF THIS LIMITED WARRANTY.

Neither dealers nor the retail establishment selling this product has any authority to make any additional warranties or to promise remedies in addition to or inconsistent with those stated above.

Manufacturer's maximum liability, in any event, shall not exceed the documented purchase price of the product paid by the original consumer.

This warranty only applies to units purchased from an authorized retailer and or re-seller.

NOTE: Some states do not allow an exclusion or limitation of incidental or consequential damages, so some of the above limitations or exclusions may not apply to you. This limited warranty gives you specific legal rights as set for herein. You may also have other rights which vary from state to state. In the state of California only, if refinishing or replacement of the product is not commercially practicable, the retailer selling this product or the Manufacturer will refund the purchase price paid for the product, less the amount directly attributable to use by the original consumer-purchaser prior to discovery of the nonconformity. In addition, in the state of California only, you may take the product to the retail establishment selling this product in order to obtain performance under this limited warranty.

If you wish to obtain performance of any obligation under this limited warranty, you should write to:

Char-Broil Consumer Relations

P. O. Box 1240

Columbus, GA 31902-1240

Consumer returns will not be accepted unless a valid Return Authorization is first acquired by calling 1-888-430-7870 and then clearly marked on the outside of the package and the package is shipped freight/postage pre-paid to the address above.

Please register your product online at:

www.grillregistration.com

(If you register online, you do not need to send in this registration card.)

PLEASE FILL OUT THIS CARD AND RETURN IT *WITHIN 10 DAYS OF PURCHASE. FAILURE TO RETURN MAY AFFECT YOUR WARRANTY COVERAGE. FOR WARRANTY SERVICE PROOF OF PURCHASE WILL BE REQUIRED. PLEASE KEEP YOUR SALES RECEIPT. THIS WARRANTY IS NON-TRANSFERABLE.*

LLENE ESTA TARJETA Y DEVUELVALA DENTRO DE LOS 10 DIAS DE LA COMPRA. *SI NO LA DEVUELVE, PUEDE VERSE AFECTADA SU COBERTURA DE GARANTIA. PARA EL SERVICIO DE GARANTIA ES NECESARIO QUE PRESENTE SU COMPROBANTE DE COMPRA. CONSERVE LA FACTURA. ESTA GARANTIA ES INTRANSFERIBLE.*

VEUILLEZ COMPLETER CETTE CARTE ET LA RETOURNER DANS LES 10 JOURS SUIVANT L'ACHAT. *LA COUVERTURE DE VOTRE GARANTIE POURRAIT EN ETRE AFFECTEE SI VOUS NE LE FAITES PAS. POUR OBTENIR LE SERVICE SOUS GARANTIE, UNE PREUVE D'ACHAT DOIT ETRE PRESENTEE. VEUILLEZ CONSERVER VOTRE FACTURE. LA PRESENTE GARANTIE N'EST PAS TRANSFERABLE.*

1 First Name/Nombre/Prénom Initial/Inicial/Initiale Last Name/Apellido/Nom de famille

Address (number and street)/Dirección (número y calle)/Adresse (numéro et rue) Apt Number/Nº de apart./Nº d'appt.

City/Ciudad/Ville State/Estado/Province Zip Code/Código zip/Code postal

2 E-mail Address/Dirección de correo electrónico/Adresse électronique

If you voluntarily provide us with your email address, you give us permission to use your email address to send you offers that may interest you. Si nos informa voluntariamente su dirección de correo electrónico, nos da permiso para usarlo a fin de enviarle ofertas que pueden interesarle. Si vous choisissez de nous fournir votre adresse électronique, vous nous donnez la permission de l'utiliser pour vous faire part d'offres spéciales susceptibles de vous intéresser.

(Example: your name @ your host.com) (Ejemplo: su nombre@su host.com) (Exemple : votre nom@votre hôte.com)

3 Phone Number/Número telefónico/Numéro de téléphone

6 Date of Purchase/Fecha de compra/Date de l'achat

4 **IMPORTANT! ¡IMPORTANTE! IMPORTANT!**

Write Serial Number and Model Number in spaces below. Escriba en los espacios de abajo el número de serie y el número de modelo. Inscrivez le numéro de série et le numéro de modèle dans les espaces ci-dessous.

7 Store Name/Nombre de la tienda/Nom du magasin

8 Purchase Price/Precio de compra/Prix d'achat

\$ _____ .00

5 Your Gender/Sexo/Sexe :

1. Male/Masculino/Masculin

2. Female/Femenino/Féminin

9 Which product are your registering?

¿Qué producto está registrando?

Quel produit enregistrez-vous?

- Gas Grill/Parrilla a gas/Gril au gaz
- Electric Grill/Parrilla eléctrica/Gril électrique
- Smoker/Ahumador/Fumoir
- Charcoal Grill/Parrilla a carbón/Barbecue au charbon
- Charcoal Smoker/Ahumador a carbón/Fumoir au charbon
- Outdoor Fireplace/Chimenea para exteriores/Foyer extérieur
- Cooker/Fryer / Cocina/freidora / Cuiseur/Friteuse
- Other/Otro/Autre

Mail to: / Envíelo a:

Consumer Warranty Service

P. O. Box 1240

Columbus, GA 31902-1240

Thank you for completing this questionnaire. Your answers will help us and other companies reach you with offers that may interest you. If you prefer not to receive these offers, please check here .

Gracias por completar este cuestionario. Sus respuestas nos ayudarán, a nosotros y a otras compañías, a llegar a usted con ofertas que puedan resultarle de interés. Si prefiere no recibir estas ofertas, por favor marque aquí .

Merci d'avoir bien voulu remplir ce questionnaire. Vos réponses nous aideront et aideront d'autres compagnies à vous communiquer des offres spéciales susceptibles de vous intéresser. Si vous préférez ne pas recevoir d'informations concernant ces offres spéciales, veuillez cocher ici .

This Page
Intentionally Blank

This Page
Intentionally Blank

STOP

Should you encounter a problem with our product

CALL US FIRST

Do not return this product to the store.

WE CAN HELP

GRILL SERVICE CENTER

1-888-430-7870

HOURS 8AM-6PM EST Mon-Fri

Please ensure your warranty registration is complete.

Grilling Safety Checklist

- Read and understand owners manual.
- Never overfill LP cylinder. Overfilled cylinders may cause freeze-up of regulator.
- Check tubes for spider webs. Ensure valves are correctly installed in burner tubes.
- Always ensure control knobs are in OFF position and regulator is attached to tank BEFORE opening tank valve to avoid low flames.
- Perform leak test regularly.

Thank You for Your Purchase!

